



Analog

Technical Specification

Version 2.3

2023-02-03

[ANALOG]

NFC Forum™

Contents

1	Introduction.....	1
1.1	Objectives.....	1
1.2	Purpose.....	1
1.3	Applicable Documents or References.....	1
1.4	Administration.....	2
1.5	Name and Logo Usage.....	3
1.6	Intellectual Property.....	3
1.7	Acknowledgements.....	3
1.8	Special Word Usage.....	3
1.9	Requirement Numbering.....	3
1.10	Notational Conventions.....	4
1.11	Abbreviations.....	5
1.12	Glossary.....	6
2	Overview.....	10
2.1	NFC Forum Devices.....	10
2.2	NFC Forum Reference Equipment.....	11
2.3	Positioning Convention.....	12
2.4	Operating Volume.....	13
3	Principles (Informative).....	14
3.1	General.....	14
3.2	Configurations for Transmission and Reception.....	14
3.3	Purpose of the NFC Forum Reference Equipment.....	14
3.4	Using the Reference Equipment.....	16
3.5	Functions Properly.....	16
3.6	Summary.....	17
4	Radio Frequency Power and Signal Interface.....	18
4.1	Poller Requirements for Power Transfer from Poller to Listener.....	18
4.2	Listener Requirements for Power Transfer from Poller to Listener.....	18
4.3	Influence of the Listener on the Operating Field.....	19
4.4	Poller Requirements for the Carrier Frequency f_c	20
4.5	Listener Requirements for the Carrier Frequency f_c	21
4.6	Poller Requirements for Resetting Listeners.....	22
4.7	Listener Requirements for Being Reset.....	22
4.8	Poller Requirements for Field Activation.....	24
4.9	Poller Requirements for Field Deactivation (Power Off Transition).....	25
4.10	Listener Requirements for Power-On.....	27
4.11	Poller Requirements for RF Collision Avoidance.....	27
4.12	Listener Requirements for Exposure to an Excessive Field Strength.....	28
5	Signal Interface Poller to Listener.....	30
5.1	Poller Requirements for Modulation Poller to Listener – NFC-A.....	30

- 5.2 Listener Requirements for Modulation Poller to Listener – NFC-A33
- 5.3 Poller Requirements for Modulation Poller to Listener – NFC-B34
- 5.4 Listener Requirements for Modulation Poller to Listener – NFC-B.....36
- 5.5 Poller Requirements for Modulation Poller to Listener – NFC-F.....37
- 5.6 Listener Requirements for Modulation Poller to Listener – NFC-F39
- 5.7 Poller Requirements for Modulation Poller to Listener – NFC-V39
- 5.8 Listener Requirements for Modulation Poller to Listener – NFC-V42
- 6 Signal Interface Listener to Poller44**
 - 6.1 Listener Requirements for Load Modulation Generic45
 - 6.2 Listener Requirements for Subcarrier Load Modulation NFC-A46
 - 6.3 Listener Requirements for Subcarrier Load Modulation NFC-B47
 - 6.4 Listener Requirements for Load Modulation NFC-F.....48
 - 6.5 Listener Requirements for Subcarrier Load Modulation NFC-V48
 - 6.6 Poller Requirements for Load Modulation Listener to Poller49
- A. Exhibit A51**
- B. Parameter Values52**
 - B.1 Operating Volume.....52
 - B.2 RF Power and Signal Interface53
 - B.3 Setup Values for NFC Forum Reference Equipment58
 - B.4 NFC Forum Listeners Antenna Category Definitions.....63
 - B.5 Calibration Procedure for Reference Pollers66
 - B.6 Calibration Procedure for Reference Listeners68
 - B.7 Nominal or Maximal Settings for NFC Forum Reference Equipment.....70
 - B.8 Orientation and Alignment of NFC Forum Reference Equipment71
- C. Design Information for NFC Forum Reference Equipment and 8-Shaped Coil.....73**
 - C.1 Reference Poller-073
 - C.2 Reference Poller-374
 - C.3 Reference Poller-675
 - C.4 Reference Poller - Bill Of Material.....76
 - C.5 Reference Listener-177
 - C.6 Reference Listener-378
 - C.7 Reference Listener-679
 - C.8 Reference Listener - Bill Of Material81
 - C.9 Mechanical Dimensions of Pollers and Listeners82
 - C.10 Printed Circuit Board (PCB) Construction of Pollers and Listeners90
 - C.11 Mechanical Dimensions and PCB Construction of 8-Shaped Coil.....92
- D. Alternative Method for Measuring V_{OV} Levels.....95**
 - D.1 New V_{OV} Monitor Circuit Description95
 - D.2 Alternative V_{OV} Measurement Procedure.....97
- E. Revision History98**

Figures

Figure 1: Poller and Listener Configuration	10
Figure 2: Reference Pollers	11
Figure 3: Reference Listeners	12
Figure 4: Operating Volume.....	13
Figure 5: NFC Forum Reference Equipment Generic Configuration	16
Figure 6: Activation of the operating field (Poller).....	25
Figure 7: Deactivation of the Operating Field (Poller).....	26
Figure 8: Modulation Poller to Listener for NFC-A	32
Figure 9: Modulation Poller to Listener for NFC-B.....	35
Figure 10: Modulation Poller to Listener for NFC-F	38
Figure 11: Modulation Poller to Listener for NFC-V	42
Figure 12: Load Modulation Listener to Poller	44
Figure 13: Start of Subcarrier Modulation – NFC-A	47
Figure 14: Allowed Phase Shifts – NFC-B.....	48
Figure 15: Start of Subcarrier Modulation – NFC-V	49
Figure 16: Example of an antenna for Category A	64
Figure 17: Example of an antenna for Category B.....	65
Figure 18: Example of an antenna for Category C.....	65
Figure 19: Example of an antenna for default Category which is Category C	66
Figure 20: Calibration Plane of SMA Plug and Socket.....	67
Figure 21: Example of VNA Display while Tuning a Reference Poller	67
Figure 22: Example of VNA Display while Tuning a 13,56MHz Reference Listener	69
Figure 23: Orientation of NFC Forum Reference Equipment Used To Characterize a Polling or Listener.....	72
Figure 24: Relative Orientation of NFC Forum Reference Equipment During Setup	72
Figure 25: Circuit for Reference Poller-0.....	73
Figure 26: PCB Layout for Reference Poller-0	73
Figure 27: Circuit for Reference Poller-3.....	74
Figure 28: PCB Layout for Reference Poller-3	74
Figure 29: Circuit for Reference Poller-6.....	75
Figure 30: PCB Layout for Reference Poller-6	75
Figure 31: Circuit for Reference Listener-1	77

Figure 32: PCB Layout for Reference Listener-178

Figure 33: Circuit for Reference Listener-3 78

Figure 34: PCB Layout for Reference Listener-3 79

Figure 35: Circuit for Reference Listener-6 79

Figure 36: PCB Layout for Reference Listener-680

Figure 37: Reference Poller-0 Top Layer..... 82

Figure 38: Reference Poller-0 Mid Layer 1..... 82

Figure 39: Reference Poller-0 Mid Layer 2..... 83

Figure 40: Reference Poller-0 Bottom Layer..... 83

Figure 41: Reference Poller-3 Top Layer..... 84

Figure 42: Reference Poller-3 Mid Layer 1..... 84

Figure 43: Reference Poller-3 Mid Layer 2..... 84

Figure 44: Reference Poller-3 Bottom Layer..... 85

Figure 45: Reference Poller-6 Top Layer..... 85

Figure 46: Reference Poller-6 Mid Layer 1..... 85

Figure 47: Reference Poller-6 Mid Layer 2..... 86

Figure 48: Reference Poller-6 Bottom Layer..... 86

Figure 49: Reference Listener-1 Top Layer 86

Figure 50: Reference Listener-1 Bottom Layer 87

Figure 51: Reference Listener-3 Top Layer 87

Figure 52: Reference Listener-3 Bottom Layer 88

Figure 53: Reference Listener-6 Top Layer 88

Figure 54: Reference Listener-6 Bottom Layer 88

Figure 55: PCB Control Drawing for Reference Poller-0 91

Figure 56: PCB Control Drawing for Reference Listener-1 92

Figure 57: 8-Shaped Coil..... 93

Figure 58: Principle of Operation of 8-Shaped Coil 94

Figure 59: Suggested Additional Circuit Arrangement..... 96

Tables

Table 1: Sample Requirement.....	4
Table 2: Notational Conventions	4
Table 3: Abbreviations	5
Table 4: Configurations Transmit and Receive	14
Table 5: Parameters for Operating Volume.....	52
Table 6: Parameters for RF Power and Modulation.....	53
Table 7: Parameters for Setting Up Reference Equipment.....	58
Table 8: NFC Forum Listener antenna size definition	63
Table 9: Category A example dimensions and limits.....	64
Table 10: Category B example dimensions and limits	65
Table 11: Category C example dimensions and limits	66
Table 12: Default Category C example dimensions and limits.....	66
Table 13: Setup for Nominal or Maximal Field Strength.....	70
Table 14: Setup for Nominal Modulation.....	71
Table 15: Revision History	98

Requirements

Requirements 4.1 — Power Transfer from Poller to Listener (Poller Transmission).....	18
Requirements 4.2 — Power Transfer from Poller to Listener (Listener Reception).....	19
Requirements 4.3 — Influence of the Listener on the Operating Field.....	20
Requirements 4.4— Carrier Frequency f_c (Poller Transmission).....	21
Requirements 4.5 — Carrier Frequency f_c (Listener Reception)	21
Requirements 4.6 — Listener Reset (Poller Transmission).....	22
Requirements 4.7 — Listener Reset (Listener Reception)	23
Requirements 4.8 — Activation of the operating field (Poller Transmission)	24
Requirements 4.9 — Deactivation of the operating field (Poller Transmission).....	26
Requirements 4.10 — Power On (Listener Reception).....	27
Requirements 4.11 — Poller RF Collision Avoidance before Carrier Generation	28
Requirements 4.12 —Excessive field strength Exposure (Listener Sustainability).....	29
Requirements 5.1 — Modulation Poller to Listener – NFC-A (Poller Transmission).....	31
Requirements 5.2 — Modulation Poller to Listener – NFC-A (Listener Reception).....	33
Requirements 5.3 — Modulation Poller to Listener – NFC-B (Poller Transmission)	35
Requirements 5.4 — Modulation Poller to Listener – NFC-B (Listener Reception).....	36
Requirements 5.5 — Modulation Poller to Listener – NFC-F (Poller Transmission).....	38
Requirements 5.6 — Modulation Poller to Listener – NFC-F (Listener Reception)	39
Requirements 5.7 — Modulation Poller to Listener – NFC-V (Poller Transmission).....	41
Requirements 5.8 — Modulation Poller to Listener – NFC-V (Listener Reception).....	43
Requirements 6.1 — Load Modulation Characteristics - Generic (Listener Transmission).....	46
Requirements 6.2 — Load Modulation Characteristics – NFC-A (Listener Transmission).....	46
Requirements 6.3 — Load Modulation Characteristics – NFC-B (Listener Transmission).....	47
Requirements 6.4 — Load Modulation Characteristics – NFC-F (Listener Transmission)	48
Requirements 6.5 — Load Modulation Characteristics – NFC-V (Listener Transmission).....	49
Requirements 6.6 — Modulation Listener to Poller (Poller Reception)	50

1 Introduction

1.1 Objectives

This document specifies the analog interface of the NFC Forum Devices for all four NFC technologies (NFC-A, NFC-B, NFC-F and NFC-V) and for all of the NFC Forum specified bit rates (26 kbps, 106 kbps, 212 kbps and 424 kbps).

This specification addresses the analog characteristics of the RF interface of the NFC Forum Devices. Its purpose is the characterization and definition of the NFC Forum Devices' externally observable signals, without limiting the design of the NFC Forum Devices' antennas. These analog characteristics include the Devices' power requirements (determining operating volume), transmission requirements, receiver requirements and signal forms (time/frequency/modulation characteristics).

Specification of the analog characteristics requires the definition of the characteristics of the signal measurement equipment. This technical specification defines the minimum measurement equipment necessary to delimit the analog interface. The equipment consists solely of the components that have direct interaction with the RF field. The various analog signals themselves still need to be measured by separate measurement equipment that is not defined in this specification.

This specification assumes that the same requirements apply, independent of the mode in which an NFC Forum Device is operating. For example: devices that are self-powered might still be capable of operation once that power has been depleted.

This document is intended for use by manufacturers planning to implement an NFC Forum Device.

1.2 Purpose

This document's purpose is the specification of the NFC Forum Devices' RF characteristics sufficiently for radio link interoperability issues to be minimized. The overall goal is to use the expertise of the NFC Forum members to develop a specification that can be used as the basis for NFC Forum Device testing and approvals.

1.3 Applicable Documents or References

The following documents contain provisions that are referenced in this specification. Unless a publication date is explicitly stated, the latest version of each document, including all published amendments, applies.

[ACTIVITY]	Activity Technical Specification, NFC Forum
[ANALOG_TC]	Test Specification/Cases for Analog Technical Specification, NFC Forum
[DIGITAL]	Digital Protocol Technical Specification, NFC Forum
[EMV_CLESS]	EMV Contactless Communication Protocol Specification, EMVCo

- [ISO/IEC_14443] Identification cards – Contactless integrated circuit cards – Proximity cards
Includes:
- [ISO/IEC 14443-1], Identification cards – Contactless integrated circuit cards – Proximity cards – Part 1: Physical characteristics
 - [ISO/IEC 14443-2], Identification cards – Contactless integrated circuit cards – Proximity cards – Part 2: Radio frequency power and signal balance
 - [ISO/IEC 14443-3], Identification cards – Contactless integrated circuit cards – Proximity cards – Part 3: Initialization and anticollision
 - [ISO/IEC 14443-4], Identification cards – Contactless integrated circuit cards – Proximity cards – Part 4: Transmission protocol
- [ISO/IEC_15693] Identification cards – Contactless integrated circuit cards – Vicinity cards
Includes:
- [ISO/IEC 15693-2], Identification cards – Contactless integrated circuit cards – Vicinity cards – Part 2: Air interface and initialization
 - [ISO/IEC 15693-3], Identification cards – Contactless integrated circuit cards – Vicinity cards – Part 3: Anticollision and transmission protocol
- [ISO/IEC_18092] Information technology – Telecommunications and information exchange between systems – Near Field Communication – Interface and Protocol (NFCIP-1)
ISO/IEC
- [RFC2119] Key words for use in RFCs to Indicate Requirement Levels, March 1997
- [T2T] Type 2 Tag Specification,
NFC Forum
- [T3T] Type 3 Tag Specification,
NFC Forum
- [T4T] Type 4 Tag Specification,
NFC Forum
- [T5T] Type 5 Tag Specification,
NFC Forum

1.4 Administration

The NFC Analog Specification is an open specification supported by the Near Field Communication Forum, Inc., located at:

401 Edgewater Place, Suite 600
Wakefield, MA, 01880

Tel.: +1 781-876-8955
Fax: +1 781-610-9864

<http://www.nfc-forum.org/>

The NFC Forum, Inc. maintains this specification.

1.5 Name and Logo Usage

The Near Field Communication Forum's policy regarding the use of the trademarks *NFC Forum* and the NFC Forum logo is as follows:

- Any company MAY claim compatibility with NFC Forum specifications, whether a member of the NFC Forum or not.
- Permission to use the NFC Forum logos is automatically granted to designated members only as stipulated on the most recent Membership Privileges document, during the period of time for which their membership dues are paid.
- Member's distributors and sales representatives MAY use the NFC Forum logo in promoting member's products sold under the name of the member.
- The logo SHALL be printed in black or in color as illustrated on the Logo Page that is available from the NFC Forum at the address above. The aspect ratio of the logo SHALL be maintained, but the size MAY be varied. Nothing MAY be added to or deleted from the logos.
- Since the NFC Forum name is a trademark of the Near Field Communication Forum, the following statement SHALL be included in all published literature and advertising material in which the name or logo appears:

NFC Forum and the NFC Forum logo are trademarks of the Near Field Communication Forum.

1.6 Intellectual Property

The NFC Forum Analog Technical Specification conforms to the Intellectual Property guidelines specified in the NFC Forum's *Intellectual Property Rights Policy*, as outlined in the NFC Forum *Rules of Procedure*. These documents are available on the [NFC Forum website](#).

1.7 Acknowledgements

Some information has been derived from [ISO/IEC_14443], [ISO/IEC_15693] and [ISO/IEC_18092].

British Standards can be obtained in PDF or hardcopy formats from the BSI online shop at www.bsigroup.com/Shop or by contacting BSI Customer Services (for hardcopies only) at +44 (0)20 8996 9001; email: cservices@bsigroup.com.

1.8 Special Word Usage

The key words “SHALL”, “SHALL NOT”, “SHOULD”, “SHOULD NOT” and “MAY” in this document are to be interpreted as described in [RFC2119].

1.9 Requirement Numbering

Requirements in this document are uniquely numbered with the number appearing next to each requirement. Table 1 shows an example.

Table 1: Sample Requirement

1.9.1.1	A car SHALL have four wheels.
----------------	-------------------------------

A requirement can have different numbers in different versions of the specifications. Hence, all references to a requirement SHALL include the version of the document as well as the requirement’s number.

1.10 Notational Conventions

The notational conventions defined in Table 2 apply to this document.

Table 2: Notational Conventions

Notation	Description
XYh	Hexadecimal notation. Hexadecimal numbers are represented using the numbers 0 - 9 and the characters A – F. An “h” is added at the end. The most significant byte (MSB) is shown on the left; the least significant byte (LSB) on the right. Example: F5h
xyb	Binary notation. Values expressed in binary form are followed by a lower case “b”. For example, 82h hexadecimal is expressed in binary as 1000010b. Binary numbers are represented by strings of the digits 0 and 1, shown with the most significant bit (msb) on the left and the least significant bit (lsb) on the right. A “b” is added at the end. Example: 11110101b
[...]	Optional part
xx	More than one value possible
STATE	Names of defined States are written in bold all-capital COURIER FONT letters.
COMMAND and RESPONSE	The defined Command and Response names are written in non-bold all-capital letters.

1.11 Abbreviations

Table 3 contains the definitions of the abbreviations and acronyms used in this specification.

Table 3: Abbreviations

Abbreviation	Description
AM	Amplitude Modulation
ASK	Amplitude Shift Keying
BPSK	Binary Phase Shift Keying
CMR	Common Mode Rejection
DC	Direct Current
DVR	Delta V_{ov} Ratio
f_c	Carrier Frequency
f_{RES}	Resonance frequency
f_s	Subcarrier frequency
IEC	International Electrotechnical Commission
ISO	International Organization for Standardization
JIS	Japanese Industrial Standard
NFC	Near Field Communication
NFC-A	Near Field Communication – Type A Technology
NFC-ACM	Near Field Communication – Active Communication Mode (based on either NFC-A or NFC-F)
NFC-B	Near Field Communication – Type B Technology
NFC-F	Near Field Communication – Type F Technology
NFC-V	Near Field Communication – Type V Technology
NFCIP-1	Near Field Communication Interface and Protocol as specified in [ISO/IEC_18092]. Specific protocol of the NFC Peer Mode.
NRZ-L	Non-Return to Zero, (L for Level)
n.a.	Not Applicable
OOK	On-Off Keying
OSL	Open, Short, Load
PCB	Printed Circuit Board
PCD	Proximity Coupling Device [ISO/IEC_14443]
PICC	Proximity Integrated Circuit Card [ISO/IEC_14443]
POS	Point of Sale
RF	Radio Frequency
SMA	Subminiature version A (plug)
VNA	Vector Network Analyzer

1.12 Glossary

8-Shaped Coil

A single winding coil consisting of two similar loops that together form a figure 8 shape. This coil is employed to capture signals that are used to analyze, for instance, waveform characteristics of Pollers.

Active Communication Mode

A communication mode in which each device generates an Operating Field when it has to send a frame to a peer device.

Activity

A process within an NFC Forum Device.

Card Emulator

Role of an NFC Forum Device, reached when an NFC Forum Device in Listen Mode has gone through a number of States. In this mode the NFC Forum Device behaves as one of the Technology Subsets.

Command

An instruction from one device to another device in order to move the other device through a state machine.

Correct Frame

A frame without Transmission Error.

Initiator

Role of a Poller when it has gone through a number of Activities. In this mode, the NFC Forum Device communicates using the NFC-DEP Protocol.

Listen Frame

A frame sent by a Listener.

Listen Mode

The mode of an NFC Forum Device where it receives Commands and sends Responses.

Listener

An NFC Forum Device in Listen Mode.

Lower Level

Term used in DIGITAL to mean V_2 for NFC-A.

Modulation Index

The modulation index of an amplitude modulated signal.

NFC Forum Device

A device that supports at least one communication protocol for at least one communication mode defined by the NFC Forum specifications. Currently the following NFC Forum Devices are defined:

NFC Universal Device, NFC Tag Device and NFC Reader Device.

NFC Forum Reference Equipment

A set of NFC Forum Reference Poller and NFC Forum Reference Listener devices in conjunction with which the radio frequency (RF) characteristics of this specification are valid.

NFC Forum Tag

A contactless tag or (smart) card supporting NDEF.

NFC-DEP Protocol

Half-duplex block transmission protocol defined in [DIGITAL].

No Remote Field Sensed

A condition that indicates the absence of the Remote Field for a certain time.

Operating Field

The radio frequency field created by the NFC Forum Device.

Operating Field Off

A condition of the Operating Field when the field strength is below a well-defined threshold.

Operating Field On

A condition of the Operating Field when the field strength is equal to or higher than a well-defined threshold for a minimum period of time.

Operating Volume

The three-dimensional space, as defined by the NFC Forum, in which an NFC Forum Device in Poll Mode can communicate with an NFC Forum Device in Listen Mode.

Passive Communication Mode

A communication mode in which one device generates an Operating Field and sends Commands to a second device. To respond, the second device uses load modulation, which means that it does not generate an Operating Field, but draws power from a Remote Field.

Poll Command

A Command to probe for Listeners

- ALL_REQ Command or SENS_REQ Command for NFC-A
- ALLB_REQ Command or SENSB_REQ Command for NFC-B
- SENSF_REQ Command for NFC-F
- INVENTORY_REQ Command for NFC-V

- ATR_REQ Command for NFC-ACM.

Poll Mode

The mode of an NFC Forum Device in which it sends Commands and receives Responses.

Poller

An NFC Forum Device in Poll Mode.

Protocol Error

A Semantic Error or Syntax Error.

Reader/Writer

Role of a Poller when it has gone through a number of Activities. In this mode, the Poller communicates with Type 2 Tags, Type 3 Tags, Type 4 Tags or Type 5 Tags.

Reference Listener

Part of the NFC Forum Reference Equipment employed to evaluate the RF characteristics of Pollers.

Reference Poller

Part of the NFC Forum Reference Equipment employed to evaluate the RF characteristics of Listeners.

Remote Field

The radio frequency field generated by a remote device and sensed by the NFC Forum Device.

Resonance Frequency

The frequency where the imaginary part of the impedance is zero is defined as resonance frequency. At this frequency the phase angle of the impedance is zero.

Response

Information sent from one device to another device upon receipt of a Command. The information received by the other device allows it to continue the data exchange.

Semantic Error

A Correct Frame with no Syntax Error is received when it is not expected.

State

A state of the Listener.

Syntax Error

A Correct Frame is received with invalid content. In this case either the coding of the Command or the block in the frame is not consistent with DIGITAL.

Target

Role of a Listener when it has gone through a number of States. In this mode the NFC Forum Device communicates using the NFC-DEP Protocol.

Technology

A group of transmission parameters defined by the NFC Forum specifications that make a complete communication protocol. A non-exhaustive list of transmission parameters is: RF carrier, communication mode, bit rate, modulation scheme, bit-level coding, frame format, protocol, and command set. The NFC Forum defines four groups of transmission parameters and therefore four Technologies: NFC-A, NFC-B, NFC-F and NFC-V. These four Technologies use the same RF carrier (13.56 MHz) and might have the same protocol and Command set. Each Technology uses its own modulation scheme, bit-level coding and frame format, but can have the same protocol and Command set.

Technology Subset

A legacy platform supporting a subset of a Technology. A Technology Subset supports at least the Poll Command of the Technology. The Technology Subsets are:

- Type 2 Tag platform, which uses a particular subset of NFC-A, including anti-collision.
- Type 3 Tag platform, which uses a particular subset of NFC-F, including anti-collision.
- Type 4 Tag platform, which uses a particular subset of NFC-A or NFC-B, including anti-collision.
- Type 5 Tag platform, which uses a particular subset of NFC-V, including anti-collision.

Timeout Error

No Response has been received within the Response Waiting Time (RWT). See DIGITAL.

Transmission Error

An incorrect frame is received. In this case, the signal modulation, the bit coding, the frame format, the timing, or the checksum is not as specified with DIGITAL.

Unmodulated Carrier

A condition of the Operating Field with no modulation present. For the purposes of this specification an unmodulated carrier is defined as one that has no discernible, detectable or measurable modulation.

Valid Block, Valid PDU

A block or protocol data unit (PDU) without Protocol Error within a Correct Frame.

Valid Command, Valid Response

A Command or Response without Protocol Error within a Correct Frame.

2 Overview

2.1 NFC Forum Devices

An NFC Forum Device is assumed to be equipped with an antenna connected to an electronic circuit. During operation the combination of two NFC Forum Devices (Poller and Listener) behaves like a transformer. An alternating current passes through a primary coil (Poller antenna) and creates an electromagnetic field that induces a current in the secondary coil (Listener antenna). The Listener might use the electromagnetic field (or radio frequency field) transmitted by the Poller to power itself. The configuration and tuning of both antennas determines the coupling efficiency from one device to the other.

Figure 1 shows a Poller and Listener configuration.

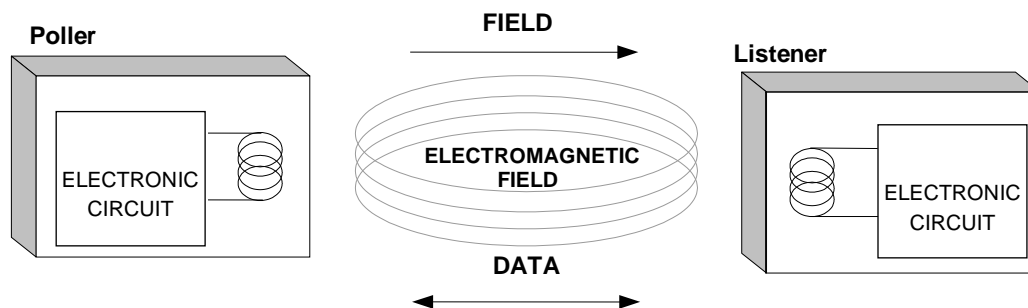

Figure 1: Poller and Listener Configuration

The addition of information to a signal carrier is called modulation. A signal carrier is characterized by means of its amplitude, phase, and frequency. Therefore, information can be added to the carrier by means of changing one or more of these characteristics. Modulation methods used in this document are:

- Amplitude modulation: the level of the signal carrier is varied over time.
- Phase modulation: the flow of the signal carrier is either advanced or delayed temporarily, giving a change in phase.

The radio frequency (RF) energy transmitted by the Poller and received by the Listener activates or wakes up the Listener and is also used to transport the data through the modulation of the carrier. The Listener decodes and processes the data and responds to the Poller by means of load modulation.

Load modulation is based on the electromagnetic coupling (i.e., mutual inductance) between the Listener and the Poller and is similar to the power transfer and communication from the Poller to the Listener. The Listener changes the current in its antenna.

The variation of the current in the Listener antenna is sensed by the Poller as a small change in the current in its antenna. This is typically sensed as a small increase in voltage across a resistor in series with the Poller antenna.

2.2 NFC Forum Reference Equipment

The RF power and signal interface part of the specification is specified in terms of the NFC Forum Reference Equipment. The NFC Forum Reference Equipment consists of two categories of devices: Reference Pollers and Reference Listeners. The purpose of the NFC Forum Reference Equipment is to act as Pollers and Listeners that cover the variations (for example, at the extremes of parameters) in NFC contactless technology. A Poller can therefore be characterized in operation with a Reference Listener, and a Listener can be characterized in operation with a Reference Poller.

In addition, an 8-Shaped Coil is specified in order to capture signals for parameter evaluation during the characterization of the Pollers and Listeners.

NFC Forum Devices, Legacy Reader/Writers, and PICCs will all utilize a range of different antenna sizes and characteristics. It is unrealistic to adopt just one size of antenna for the NFC Forum Reference Equipment for the RF Analog specification to cover all modes of operation.

During interoperation there will likely be “worst case” combinations of the Initiator device antenna relative to the Target device or tag antenna:

- Large relative to small (e.g., POS terminal to small handset, or large handset to small tag)
- Small relative to large (e.g., small to large handset or small handset to large tag)
- Same relative to same (mobile to mobile, due to interaction at close ranges)

There is no requirement to create NFC Forum Devices using the architecture, antenna layout and resonance frequency used for the Reference Pollers or the Reference Listeners. The NFC Forum Reference Equipment is put in place only to specify an externally observable behavior.

The aim is that sufficient documentation will be available to allow users to construct and calibrate their NFC Forum Reference Equipment or to purchase it from vendors.

The designs of the NFC Forum Reference Equipment and the 8-Shaped Coil are specified in Appendix C.

2.2.1 Reference Poller

When it is connected to a suitable signal generator and power amplifier, a Reference Poller allows commands to be sent to a Listener. The response from a Listener might then be captured and analyzed by means of associated measurement equipment.

The Reference Pollers with three different antenna coil designs are based on the standard [EMV_CLESS] PCD (for Poller-0) and compensated versions of two of the ISO standardized PICC antenna coil designs (Poller-3 and 6).

Figure 2 shows the Reference Pollers (Poller-0, Poller-3, and Poller-6), presented in left to right order. Appendices C.1, C.2 and C.3 give the full design details. Appendix C.8 describes the mechanical dimensions.



Figure 2: Reference Pollers

2.2.2 Reference Listener

The Reference Listeners are specified with three forms of antenna coil design geometry.

The coil geometries of Listener-1, Listener-3 and Listener-6 are based on the outside envelope measurements of the ISO referenced PICC-1, PICC-3 and PICC-6 antenna designations, respectively.

The PCB coil designs are not necessarily identical and revisions might be required for synchronization.

The Reference Listener can also send information back to a Poller, using various levels of load modulation generated using a suitable signal source.

Two resonance frequencies, 13.56 MHz and 16 MHz, are defined for the Reference Listener.

There is no requirement to create one Reference Listener PCB configurable for the two resonance frequencies or two Reference Listener PCBs each configured to one resonance frequency.

The Reference Listener can be configured to use a number of fixed resistive loads. These resistive load settings can be used to represent both the typical and the worst-case scenarios to be encountered by a Poller.

Figure 3 shows the Reference Listeners (Listener-1, Listener-3 and Listener-6), presented in left-to-right order. Appendices C.5, C.6 and C.7 give the full design details. Appendix C.9 describes the mechanical dimensions.



Figure 3: Reference Listeners

2.2.3 8-Shaped Coil

The 8-Shaped Coil is a single winding coil, consisting of two similar loops that form a figure 8 shape. There is no component other than a connector towards a high impedance measurement device.

The 8-Shaped Coil enables capture of the signal sent by the Poller when the Listener is present in the Operating Volume.

The 8-Shaped Coil is used to analyze the waveforms of the captured signals.

The 8-Shaped Coil is constructed on flexible PCB to optimize its positioning on the surface of the Poller.

The resonance frequency of the 8-Shaped Coil SHALL be higher than 80MHz in order to minimize any influences on the measured signals of the Poller.

Annex C.11 describes in more detail the construction requirements for the 8-Shaped Coil.

2.3 Positioning Convention

The specification is based on the existence of Reference Marks presumed to be on the casing of the NFC Forum Devices and against which parameters in the specifications are defined.

This specification assumes planar devices oriented in a parallel configuration.

2.4 Operating Volume

The Operating Volume of a Poller is the 3-dimensional space for which this specification imposes requirements with the aim of ensuring interoperability between NFC devices over at least this volume.

Figure 4 shows the geometry of the Operating Volume.

The Operating Volume is measured from the Reference Mark, along an axis perpendicular to the device. Requirements on this geometry suppose that the Poller is stationary and that the Listener moves slowly (less than 1 m/s) through the Operating Volume, or vice versa.

The position of a Listener within the Operating Volume is represented by the quadruplet (z, r, φ, θ) . Positioning conventions for this are not defined in this technical specification; please refer to [ANALOG_TC].

Appendix B.1 defines the values of the symbols used in Figure 4.

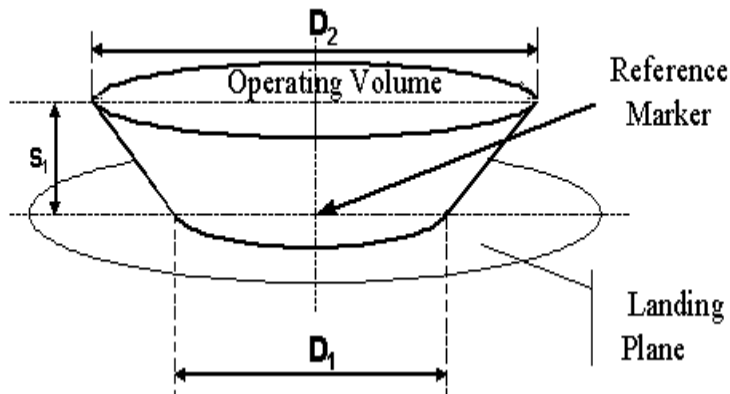

Figure 4: Operating Volume

The Poller uses the Reference Marker as the point to indicate the origin of the Operating Volume ($z=0, r=0, \varphi=0, \theta=0$).

3 Principles (Informative)

3.1 General

This section describes the principles by which the requirements included in this document are specified with respect to the NFC Forum Reference Equipment (as defined by the NFC Forum and presented in Appendix C).

Each Requirement statement is preceded by a description of the conditions under which the NFC Forum Reference Equipment is used and the conditions under which the specification requirement is valid.

The remainder of this section explains the approach used for writing the requirements.

3.2 Configurations for Transmission and Reception

An NFC Forum Device, which can be a Poller or a Listener, is either transmitting or receiving at one time.

A Poller transmits power and data to a Listener and receives data from this Listener. A Listener might receive power as well as data from a Poller and can transmit data to the Poller. The configurations for transmitting and receiving for a Poller and a Listener are illustrated in Table 4.

Table 4: Configurations Transmit and Receive

	Poller		Listener	
	Transmit	Receive	Transmit	Receive
Power	√	n.a.	n.a.	√
Data	√	√	√	√

For each device the requirements related to transmission are such that the value of a transmit parameter (X) will fall within a defined range R_{tx} , from X_{tx} min to X_{tx} max. The requirements on reception are such that the receiver will work properly with the values of the different parameters varying over a range R_{rx} from X_{rx} min to X_{rx} max, as are relevant for each parameter. For interoperability the ranges for the corresponding transmission and reception parameters are defined so that the range of X_{tx} is contained within the range for X_{rx} .

3.3 Purpose of the NFC Forum Reference Equipment

The transmission requirements and characteristics of an NFC Forum Device are valid in the presence of the receiving antenna of the appropriate NFC Forum Reference Equipment. For example, whether the transmitter of a Poller meets the requirements is characterized by means of the Reference Listener. Similarly, the quality of the transmitter of a Listener is characterized via the Reference Poller.

Example:

To enable operation, a Poller needs to provide a certain level of field strength (power) to a Listener. The field strength delivered by the Poller is characterized by the voltage output from J1 of a Reference Listener. The value of the field level characterized via a Reference Listener SHALL fall within the min to max range of $R_{tx,power}$.

Whether a device meets the reception requirements, or not, is characterized by setting up the transmitter of the appropriate NFC Forum – Reference Equipment to create a range of values for a number of parameters. For example, whether the receiver of a Poller meets the requirements is measured by having the Reference Listener send out different levels of load modulation. The quality of the receiver of a Listener is verified by having the Reference Poller send out levels of modulation that are slightly beyond the level of acceptability.

To set up the transmitter of the NFC Forum – Reference Equipment, the receiver of the matching NFC Forum – Reference Equipment is used. For example, the load modulation level of the Reference Listener is set up by means of and with respect to the Reference Poller. The modulation level of the Reference Poller is set up by means of and with respect to the Reference Listener.

Example:

A Listener needs to operate with a certain power level provided by a Poller. The Reference Poller generates different power levels, varying over a min to max range of $R_{rx,power}$. The power level of the Reference Poller is set up with respect to the Reference Listener. This means that $R_{rx,power}$ is a value measured on the Reference Listener and that the power level of the signal generator feeding the Reference Poller is increased/decreased until the correct (voltage) level is reached on the Reference Listener.

Since each of the parameters is specified separately, the intention is that their specifications allow them to be observed independently, as much as possible. For example, in order to measure a Listener's ability to respond to commands sent with a wide range of modulation indices, these commands are sent using a 'nominal' power level. This power level first needs to be established as described in Appendix B.7 .

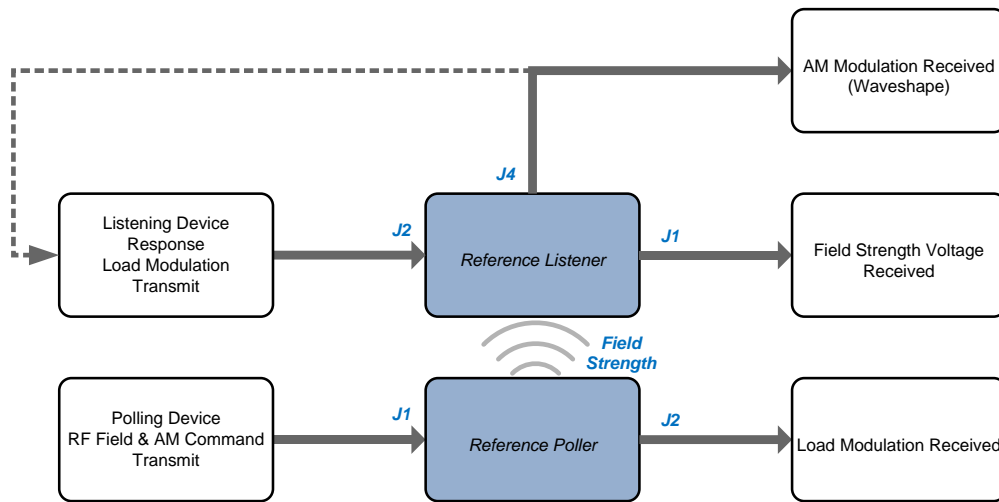

Figure 5: NFC Forum Reference Equipment Generic Configuration

3.4 Using the Reference Equipment

It is impractical to characterize an NFC Forum Device’s operation with all possible combinations of NFC Forum Reference Equipment. The testing technique proposed, therefore, is to always use the worst case counterpart for a parameter that might either be the “best-coupling” or “worst-coupling” device, depending on the specific parameter.

For example, when the minimum operating field power of a Poller is being considered, the “worst coupling” device would be used, as all other devices would give better results than this. Of course, for the maximum operating field power, the “best coupling” device would be used, as this represents the most stringent case for a listener, because the power level received for all other Reference Listener would be lower than this.

The procedure for determining the “best coupling” and “worst coupling” devices, as well as which to use for testing each parameter, is specified in the Analog Test Specification.

3.5 Functions Properly

For both a Poller and a Listener, checking the data reception characteristics depends on some kind of acknowledgement by the device that the data were received. For a Poller the operation of sending the next command (i.e., data transmission) in the overall flow implies that the response from the Reference Listener was understood. For a Listener the operation of responding to the command or a change in internal state implies that the command from the Reference Poller was understood.

For the remainder of this technical specification the term “function properly” is applied to a Poller that, following a response created by the Reference Listener, sends the next command.

For the remainder of this specification the term “function properly” is applied to a Listener that receives a command generated by the Reference Poller and that the received command results in the Listener sending the expected response or changing its internal state in a way that corresponds to the command. A change in internal state is observed when the Listener processes the next command, as anticipated.

3.6 Summary

The approach explained above leads to the following with regard to power and data transfer:

- Power provided by a Poller is specified as that power received on the Reference Listener.
- Data transmission by a Poller (e.g., modulation depth) is specified as that received on the Reference Listener.
- Data reception by a Poller (load modulation sensitivity) is specified as that generated by different signals from the Reference Listener. To determine the levels and characteristics of the signal generated by the Reference Listener, the signal is first set up with respect to the Reference Poller.
- Data transmission by a Listener is specified as that observed on the Reference Poller, with the Reference Poller providing a ‘nominal’ and ‘maximal’ power level to the Listener. Both the power level and the command characteristics produced by the Reference Poller are set up with respect to the Reference Listener.
- Power and data reception sensitivity of a Listener are specified as those observed by means of the Reference Poller, with the Reference Poller sending commands with power levels and modulation characteristics at the border of the tolerance interval R_{rx} . Again, for setting these extreme values the power and command characteristics produced by the Reference Poller are set up with respect to the Reference Listener.

4 Radio Frequency Power and Signal Interface

This section specifies the requirements for the power transfer from Poller to Listener through the electromagnetic field that is created by the Poller and that has the parameter values listed in Appendix B.2.

All specifications described in this section are only applicable in conjunction with the Reference Poller and the Reference Listener configured and set up as specified in the particular specification context listed for the requirement. The setup parameters and calibration procedures are described in Appendices B.3, B.5 and B.6.

The position of a Listener within the Operating Volume is indicated according to the convention specified in sections 2.2.3 and 2.4, using the parameter values given in Appendix B.1.

4.1 Poller Requirements for Power Transfer from Poller to Listener

This section specifies the Poller requirement for power transfer from the Poller to the Listener.

4.1.1 Specification Purpose

The purpose of this requirement is to ensure that the Poller provides an Operating Field with RF field strength within the minimum and maximum limits for powering a Listener.

4.1.2 Specification Context

- A Poller is set to emit an Operating Field without any modulation – Operating Field On.
- A Reference Listener is configured with a selected resistive load and resonance frequency (see R_L and f_{RES} for V_{OV} in Appendix B.2). See Appendix C.4 for design details.
- The Reference Listener is placed in the Operating Volume of the Poller.
- The load modulation transmit signal is not applied to J2 of the Reference Listener.

Requirements 4.1 — Power Transfer from Poller to Listener (Poller Transmission)

Poller	
4.1.2.1	<p>When the Reference Listener is located within the Operating Volume of the Poller, under the conditions described in the specification context above, it SHALL generate an output voltage V_{OV} at J1 of the Reference Listener. The average value over a small period of time ($> 10 \mu s$) at a fixed location of the voltage V_{OV} SHALL be characterized.</p> <p>Refer to Appendix B.2 for the minimum and maximum values of the range of V_{OV}.</p>

4.2 Listener Requirements for Power Transfer from Poller to Listener

This section specifies the Listener requirements for power transfer from Poller to Listener.

4.2.1 Specification Purpose

The purpose of these requirements is to ensure that the Listener functions properly in the Operating Field of the Reference Poller with a defined range of field strength.

4.2.2 Specification Context

- A Reference Poller is generating an Operating Field, with no AM modulation applied, with frequency $f_{s,c}$ (nominal value).
- A Reference Listener is configured with a fixed resistive load and resonance frequency (see $R_{s,L}$ and $f_{s,RES}$ in Appendix B.3) and with no load modulation transmit signal applied to J2.
- The carrier level of the Reference Poller, with no AM modulation applied, is set up such that the Reference Listener in position ($z=Z_{s,ov}$, $r=0$, $\phi=0$, $\theta=0$) of the Operating Volume has a voltage $V_{s,ov}$ at J1, (between min and max), as specified in Appendix B.3.
- The Reference Poller is then set up to modulate the carrier with **nominal** modulation characteristics, as detected from the sense coil via J4 of the Reference Listener, as specified in Appendix B.3.
- The Listener is then placed into the operating volume of the Reference Poller.

Requirements 4.2 — Power Transfer from Poller to Listener (Listener Reception)

Listener	
4.2.2.1	A Listener SHALL function properly within the Operating Volume of the Reference Poller when the operating conditions have been established as described in the specification context above for NFC-A. See Section 3.5 for the definition of “function properly”.
4.2.2.2	A Listener SHALL function properly within the Operating Volume of the Reference Poller when the operating conditions have been established as described in the specification context above for NFC-B.
4.2.2.3	A Listener SHALL function properly within the Operating Volume of the Reference Poller when the operating conditions have been established as described in the specification context above for NFC-F.
4.2.2.4	A Listener SHALL function properly within the Operating Volume of the Reference Poller when the operating conditions have been established as described in the specification context above for NFC-V.

4.3 Influence of the Listener on the Operating Field

Due to the electromagnetic coupling (i.e., mutual inductance) between the Listener and Poller antennas, the Listener changes the Operating Field created by the Poller when brought into its Operating Volume. The magnetic field strength within the Operating Volume will decrease due to the extra load caused by the Listener. This section specifies the Listener requirement that limits the maximum load a Listener is allowed to present to a Poller.

4.3.1 Specification Purpose

The purpose of these requirements is to specify a limit on the loading that a Listener can place on a Poller. If no limit was to be imposed, a Listener might cause so much influence on the operating field that attempting to measure the other analog parameters would be meaningless.

4.3.2 Specification Context

- A Reference Poller is generating an Operating Field, with no AM modulation applied, with frequency $f_{s,c}$ (nominal value).
- A Reference Listener is configured with a fixed resistive load and resonance frequency (see R_L and $f_{s,RES}$ for **DVR** in Appendix B.2) and with no load modulation transmit signal applied to J2.
- The Reference Poller carrier level without modulation is set up with the Reference Listener in position ($z=Z_{s,OV}$, $r=0$, $\varphi=0$, $\theta=0$) of its Operating Volume, such that the **minimum** voltage defined by $V_{s,OV}$ (as specified in Appendix B.3 is detected at J1 of the Reference Listener.

Requirements 4.3 — Influence of the Listener on the Operating Field

Listener	
4.3.2.1	<p>When the Listener is placed in the Operating Volume of the Reference Poller, the loading caused by the Listener SHALL be equal to or less than the loading caused by the Reference Listeners.</p> <p>The associated parameter DVR is defined as the ratio between the loading of the Listener under test and the loading of the Reference Listener.</p> <p>The Listener loading is defined as the maximum voltage drop, ΔV_{OV}, that is detected across the sense resistor via J2 of the Reference Poller.</p> <p>The ΔV_{OV} is the difference in the peak to peak voltage level before ($V_{OV, FREE AIR}$) and after ($V_{OV, Listener}$) the Listener is placed in the Operating Volume of the Reference Poller.</p> <p>$\Delta V_{OV, DUT} = V_{OV, FREE AIR} - V_{OV, DUT}$ detected at J2 of the Reference Poller.</p> <p>$DVR_{Poller-0} = \Delta V_{OV, DUT} / \Delta V_{OV, P0-L1}(0, 0, 0, 0)$</p> <p>$DVR_{Poller-3} = \Delta V_{OV, DUT} / \Delta V_{OV, P3-L3}(0, 0, 0, 0)$</p> <p>$DVR_{Poller-6} = \Delta V_{OV, DUT} / \Delta V_{OV, P6-L6}(0, 0, 0, 0)$,</p> <p>where $\Delta V_{OV, Px-Lx}$ is measured with the respective Reference Poller and Listener Equipment, and (0,0,0,0) indicates the origin of the Operating Volume ($z=0$, $r=0$, $\varphi=0$, $\theta=0$).</p> <p>Refer to Appendix B.2 for the value of DVR.</p>

NOTE Here the loading effect of the Listener applies irrespective of power conditions, e.g. whether the device is battery powered or not.

4.4 Poller Requirements for the Carrier Frequency f_c

This section specifies the Poller requirement for the frequency of the Operating Field (i.e., the carrier frequency f_c) created by the Poller.

4.4.1 Specification Purpose

The purpose of these requirements is to specify the limits on the carrier frequency of a Poller, to ensure that it remains within the limits expected by a Listener.

4.4.2 Specification Context

- A Reference Listener is configured with fixed resistive load and resonance frequency (see R_L and $f_{S,RES}$ for f_c in Appendix B.2) and with no load modulation signal applied to J2.
- A Poller is set to emit a carrier.
- The Reference Listener is placed in the Operating Volume of the Poller, and the sense coil of Reference Listener is used to recover the carrier for frequency measurement on J4.

Requirements 4.4— Carrier Frequency f_c (Poller Transmission)

Poller	
4.4.2.1	The frequency of the Operating Field (carrier frequency) generated by the Poller SHALL be within the range of min to max values of f_c . Refer to Appendix B.2 for the min and max range values of f_c .

4.5 Listener Requirements for the Carrier Frequency f_c

This section specifies the Listener requirement for the frequency of the Operating Field (i.e., the carrier frequency f_c).

4.5.1 Specification Purpose

The purpose of this requirement is to verify that a Listener is able to function properly when it is in an Operating Field whose carrier frequency is set between the minimum and maximum values.

4.5.2 Specification Context

- Reference Poller is generating a carrier signal with frequency $f_{s,c}$, where the range of $f_{s,c}$ is defined in Appendix B.3.
- Reference Poller is set up to send a polling command with **nominal** power transfer and modulation characteristics, as specified in Appendix B.3.

Requirements 4.5 — Carrier Frequency f_c (Listener Reception)

Listener	
4.5.2.1	When placed in the Operating Volume of the Reference Poller, the Listener SHALL function properly with a carrier frequency that is generated by the Reference Poller and that stays between the minimum and maximum values of $f_{s,c}$ (as defined in Appendix B.3).

4.6 Poller Requirements for Resetting Listeners

This section specifies how the Poller uses the Operating Field to reset the Listener in order to ensure that the Listener is correctly reset.

4.6.1 Specification Purpose

The purpose of these requirements is to specify how the Operating Field is correctly managed by the Poller to induce a reset of the Listener. This entails both that any residual carrier emitted by the Poller during the reset is sufficiently low that the Listener correctly recognizes it as a reset and that the level is maintained at this low state for a sufficient duration to induce a reset.

4.6.2 Specification Context

- Poller is set to emit a carrier without any modulation.
- The Reference Listener-6 is configured with a fixed resistive load and resonance frequency (see R_L and f_{RES} for maximum V_{OV} in Appendix B.2) and with no modulation applied to J2.
- The Reference Listener-6 is placed in the Operating Volume of the Poller and is used to capture the Poller signal on its sense coil on J4.
- Poller is induced to perform a reset.

Requirements 4.6 — Listener Reset (Poller Transmission)

Poller	
4.6.2.1	When the NFC Forum - Reference Listener-6 is within the Operating Volume of the Poller and the Poller resets the Operating Field, it SHALL NOT generate any field for a time t_{FIELD_OFF} defined by [ACTIVITY], characterized at the output of the sense coil on J4 of the NFC Forum - Reference Listener-6.

4.7 Listener Requirements for Being Reset

This section specifies the reset requirements for the Listener such that it can be ensured that a Listener can be correctly reset by a Poller that is emitting the worst case residual carrier level.

4.7.1 Specification Purpose

The purpose of these requirements is to ensure that a Listener will be correctly reset by a Poller operating according to this specification.

4.7.2 Specification Context

- The Reference Listener-6 is configured with a fixed resistive load and resonance frequency (see $R_{S,L}$ and $f_{S,RES}$ for $V_{S,OV,RESET}$ and $V_{S,OV,RESET,T5T}$ in Appendix B.3) and with no modulation applied to J2.
- The Reference Poller-0 is emitting a carrier signal with frequency $f_{s,c}$ (nominal value).

- The Reference Poller-0 carrier level is set up such that, when the Reference Listener-6 is placed in the Operating Volume at position ($z=Z_{S,OV}$, $r=0$, $\varphi=0$, $\theta=0$), it generates the maximum residual level of voltage $V_{S,OV,RESET}$ (rms) at the output of the sense coil, J4 of the Reference Listener-6. If the Listener under test is a T5T, the generated voltage SHALL be the maximum value of $V_{S,OV,RESET,T5T}$, as measured on J4 of the Reference Listener-6. Measure and record the according J2 voltage value of the Reference Poller-0.

The resulting voltage measured at J2 of the Reference Poller-0 is referenced below as $V_{GEN,J2,RESET}$.

Refer to Appendix B.3 for the value of $V_{S,OV,RESET}$ and $V_{S,OV,RESET,T5T}$.

- With the Listener in the Operating Volume at position ($z=Z_{S,OV}$, $r=0$, $\varphi=0$, $\theta=0$) of the Reference Poller-0, the following sequence SHALL cause the Listener to finish in the IDLE state:
 - The Reference Poller-0 is generating an Operating Field, with no modulation applied, with frequency $f_{S,C}$ (nominal value).
 - The Reference Listener-1 is configured with a fixed resistive load and resonance frequency (see $R_{S,L}$ and $f_{S,RES}$ for $V_{S,OV}$ minimum level in Appendix B.3) and with no load modulation transmit signal applied to J2.
 - The carrier level of the Reference Poller-0, with no AM modulation applied and the signal generator set up such that the Reference Listener-1 in position ($z=Z_{S,OV}$, $r=0$, $\varphi=0$, $\theta=0$) of the Operating Volume, now has the voltage according to the minimum level of $V_{S,OV}$ in Appendix B.3 at its output J1. The settings of the signal generator creating this voltage are referenced below as $V_{GEN,MINIMUM}$.
 - Reference Poller-0 sends the appropriate commands to put a Listener of NFC-A, NFC-B or NFC-F into an appropriate state higher than the IDLE state or a Listener of NFC-V into an appropriate state higher than the READY state, and these commands are sent to the Listener from the Reference Poller-0.
 - The signal generator level is reduced from $V_{GEN,MINIMUM}$ such that the signal observed at J2 of the Reference Poller-0 reaches $V_{GEN,J2,RESET}$ for a time t_{FIELD_OFF} specified in [ACTIVITY], before reapplying the level that was called $V_{GEN,MINIMUM}$ above.

Requirements 4.7 — Listener Reset (Listener Reception)

Listener	
4.7.2.1	When the Operating Field is switched off (as simulated by the signal generator level being reduced from $V_{GEN,MINIMUM}$ to a value leading to $V_{GEN,J2,RESET}$ at J2 of the Reference Poller-0 for a time t_{FIELD_OFF} defined by [ACTIVITY]), a Listener SHALL enter the NO_REMOTE_FIELD state, as defined in [ACTIVITY]. After the signal level is restored back to $V_{GEN,MINIMUM}$, the Listener SHALL be in the IDLE state after a time GT_A , GT_B , GT_F and GT_V . Refer to DIGITAL for the values of GT_A , GT_B , GT_F and GT_V .

NOTE This requirement assumes that the NFC Forum Devices is configured to Listen mode only.

4.8 Poller Requirements for Field Activation

This section specifies the field activation timing requirements.

4.8.1 Specification Purpose

The purpose of these requirements is to specify how a Poller has to switch on its operating RF field.

4.8.2 Specification Context

- A Reference Listener is configured with a fixed resistive load and resonance frequency (see R_L and $f_{S,RES}$ for $t_{FIELD,ACT}$ in Appendix B.2) and with no modulation transmit signal applied to J2.
- A Poller is set to emit a constant unmodulated carrier field to the Reference Listener
- The Reference Listener is placed in the NFC Forum setup position ($Z_{S,OV}$) of the Poller.
- The output voltage V_{OV} at J1 of the Reference Listener is measured as $V_{OV,MEASURED}$.
- The signal transmitted by the Poller before and after the field activation is received and characterized at the output of the 8-Shaped Coil, as described in Appendix C.

In this section the symbol V represents the envelope of the signal monitored at the output of the 8-Shaped Coil (described in Appendix C) with the Reference Listener placed in the setup position ($Z_{S,OV}$) of the Poller.

Figure 6 shows a representation of the activation of the Operating field. V_1 , and V_2 are introduced in section 5.1.2. $V_{RF\ Collision\ Avoidance}$ is defined as follows:

$$V_{RF\ Collision\ Avoidance} = (V_{OV,MIN}/V_{OV,MEASURED}) * 0.6 * V_1$$

NOTE At the position where $V_{OV,MIN}$ is measured, 15% V/V_1 corresponds to $V_{OV,RF\ Collision\ Avoidance}$, when measured with the Reference Listener-1. Consequently, in each position where $V_{OV,MIN}$ is exceeded, 15% V/V_1 results in a larger field than the $V_{RF\ Collision\ Avoidance}$ level, assuming a homogenous field in the area of the Listener's main coil. The $V_{RF\ Collision\ Avoidance}$ according field levels always exceeds the $V_{OV,RF\ Collision\ Avoidance}$ level.

Requirements 4.8 — Activation of the operating field (Poller Transmission)

Poller	
4.8.2.1	When measured as described in the specification context above, the Poller SHALL switch ON the Operating Field in the Operating Volume in such a way that the signal monitored at the output of the 8-Shaped Coil (described in Appendix C) meets the following conditions: <p style="margin-left: 40px;">The time between V_2 of the rising edge and the time when the signal exceeds $V_{RF\ Collision\ Avoidance}$ SHALL be $t_{FIELD,ACT}$.</p> <p style="margin-left: 40px;">Refer to Appendix B.2 for the values of $t_{FIELD,ACT}$.</p>

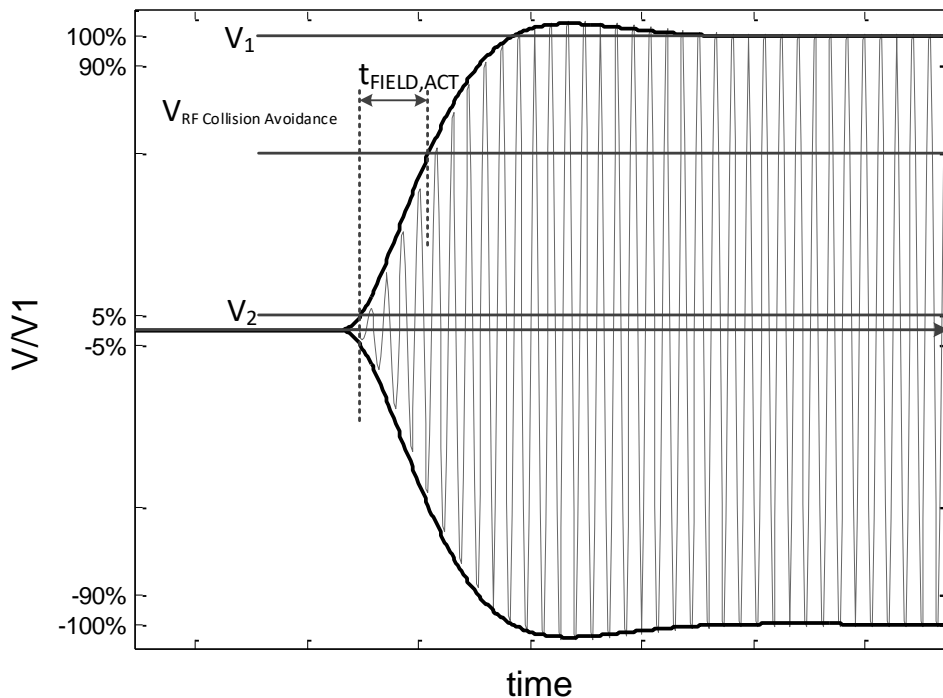

Figure 6: Activation of the operating field (Poller)

4.9 Poller Requirements for Field Deactivation (Power Off Transition)

This section specifies field deactivation timing requirements.

4.9.1 Specification Purpose

The purpose of these requirements is to specify how a Poller has to switch off its operating RF field for the Active Communication Mode.

4.9.2 Specification Context

- A Reference Listener is configured with a fixed resistive load and resonance frequency (see R_L and $f_{S,RES}$ for $t_{FIELD,DEACT}$ in Appendix B.2) and with no modulation applied to J2.
- A Poller is set to emit a constant unmodulated carrier field to the Reference Listener.
- The Reference Listener is placed in the NFC Forum setup position of the Poller ($Z_{S,OV}$).
- The signal transmitted by the Poller before and after the field deactivation is received and characterized at the output of the 8-Shaped Coil, as described in Appendix C.

In this section the symbol V represents the envelope of the signal monitored at the output of the 8-Shaped Coil (described in Appendix C) with the Reference Listener placed in the setup position ($Z_{S,OV}$) of the Poller.

Figure 7 shows a representation of the deactivation (Power OFF transition) of the Operating Field. V_1 , V_2 and V_4 are introduced in section 5.1.2.

NOTE At the position where $V_{OV,MIN}$ is measured, approximately 15% of V/V_1 corresponds to $V_{OV,RF \text{ Collision Avoidance}}$, when measured with the Reference Listener-1. V_2 is defined as 5% V/V_1 and therefore is significantly below this value, assuming a homogenous field in the area of the Listener's main coil.

Requirements 4.9 — Deactivation of the operating field (Poller Transmission)

Poller

4.9.2.1 When measured as described in the specification context above, the Poller SHALL switch OFF its Operating Field in the Operating Volume in such a way that the signal monitored at the output of the 8-Shaped Coil (described in Appendix C) meets the following conditions:

The time between V_4 of the falling edge and the time when the signal remains below V_2 SHALL be $t_{FIELD,DEACT}$.

Refer to Appendix B.2 for the values of $t_{FIELD,DEACT}$.

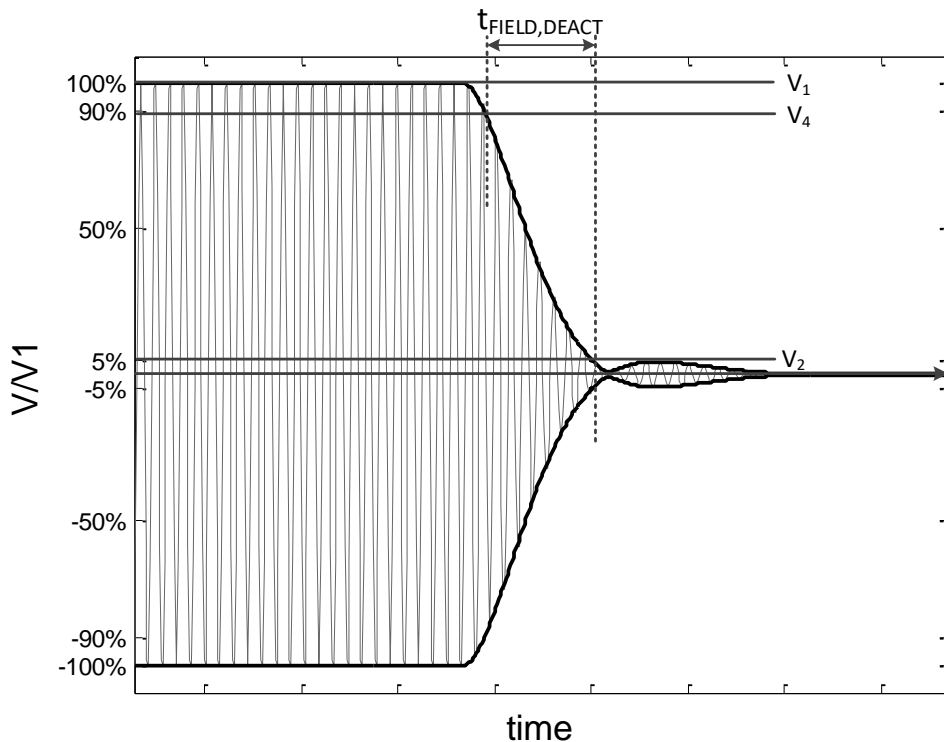

Figure 7: Deactivation of the Operating Field (Poller)

4.10 Listener Requirements for Power-On

This section specifies the Power-On requirements for the Listener.

4.10.1 Specification Purpose

The purpose of these requirements is to ensure that the Listener will be able to respond to a Poll Command that is issued after a Power On condition, within the limits of the Operating Field that might be applied by a Poller.

4.10.2 Specification Context

- A Reference Poller is generating an Operating Field, with no modulation applied, with frequency $f_{s,c}$ (nominal value).
- The Reference Poller is set to a power level between the minimum and maximum, as specified in Appendix B.3.
- The Reference Poller is set to send a polling command with **nominal** modulation characteristics, as specified in Appendix B.3, after a delay of GT_A , GT_B , GT_F and GT_V , following activation of the carrier.

Requirements 4.10 — Power On (Listener Reception)

Listener	
4.10.2.1	<p>If a Listener in NO_REMOTE_FIELD state is placed in the Operating Volume of the Reference Poller set up to be between the Min and Max power levels of Operating Field that might be provided by a Poller, it SHALL enter the IDLE state within a time GT_A, GT_B, GT_F and GT_V.</p> <p>Refer to DIGITAL for the values of GT_A, GT_B, GT_F and GT_V. Refer to [ACTIVITY] for details on the NO_REMOTE_FIELD and IDLE states.</p>

4.11 Poller Requirements for RF Collision Avoidance

This section specifies the listen before carrier generation “RF Collision Avoidance” requirement for a Poller.

4.11.1 Specification Purpose

The purpose of these requirements is to ensure that an NFC Device will be prevented from generating a carrier while it is in the presence of another Poller that is already generating a carrier — so that it will not cause interference to another Poller operating in close proximity.

4.11.2 Specification Context

- A Reference Poller is emitting a carrier signal with frequency $f_{s,c}$ (nominal value).
- The carrier level of a Reference Poller is set such that, when a Reference Listener that is configured with a fixed resistive load and resonance frequency (see $R_{s,L}$ and $f_{s,RES}$ for $V_{s,thresh}$ RF Collision Avoidance in Appendix B.3) is placed at position ($z=Z_{s,OV}$, $r=0$, $\phi=0$, $\theta=0$), it generates a voltage of $V_{s,thresh}$ RF Collision Avoidance at the output J1 of the Reference Listener.
- Refer to Appendix B.3 for the values of $R_{s,L}$, $Z_{s,OV}$ and $V_{s,thresh}$ RF Collision Avoidance.

Requirements 4.11 — Poller RF Collision Avoidance before Carrier Generation

Poller

- 4.11.2.1** With the Reference Poller preset to generate an Operating Field level determined by $V_{s,thresh\ RF\ Collision\ Avoidance}$, as given in Appendix B.3, and placed in the Operating Volume of the Poller at position ($z=Z_{s,ov}$, $r=0$, $\varphi=0$, $\theta=0$), then, when the Poller is instructed to switch on its Operating Field, it SHALL not generate an Operating Field.

4.12 Listener Requirements for Exposure to an Excessive Field Strength

This section specifies the “sustainability” requirements for the Listener such that it can be ensured that a Listener SHALL continue to operate as intended after continuous exposure to an excessive magnetic field.

4.12.1 Specification Purpose

The purpose of these requirements is to ensure that the Listener functions properly after excessive Operating Field exposure of the Reference Poller.

NOTE This definition is adopted from the definition in ISO/IEC 14443-1.

4.12.2 Specification Context

- The Reference Listener-1 is configured with a fixed resistive load and resonance frequency (see $R_{s,L}$ and $f_{s,RES}$ for $V_{s,ov,MAX10}$ in Appendix B.3) and with no modulation applied to J2.
- The Reference Poller-0 is emitting a carrier signal with frequency $f_{s,c}$ (nominal value).
- The carrier level of the Reference Poller-0, with no AM modulation applied, is set up such that, when the Reference Listener-1 is placed at position ($z=Z_{s,ov}$, $r=0$, $\varphi=0$, $\theta=0$) of the Operating Volume, it generates a voltage of $V_{s,ov,MAX10}$ at the output J1 of the Reference Listener-1. Measure and record the according J2 voltage value of the Reference Poller-0. The voltage measured at J2 of the Reference Poller-0 is referenced below as $V_{GEN,J2,MAX10}$.

Refer to Appendix B.3 for the value of $V_{s,ov,MAX10}$.

- The carrier level of the Reference Poller-0, with no AM modulation applied, is set up such that, when the Reference Listener-1 is placed at position ($z=Z_{s,ov}$, $r=0$, $\varphi=0$, $\theta=0$) of the Operating Volume, it generates a voltage of $V_{s,ov,MAX12}$ at the output J1 of the Reference Listener-1. Measure and record the according J2 voltage value of the Reference Poller-0. The voltage measured at J2 of the Reference Poller-0 is referenced below as $V_{GEN,J2,MAX12}$.

Refer to Appendix B.3 for the value of $V_{s,ov,MAX12}$.

- With the Listener in the Operating Volume at position ($z=Z_{s,ov}$, $r=0$, $\varphi=0$, $\theta=0$) of the Reference Poller-0, the following sequence SHALL be applied:
 - Reference Poller-0 is generating an Operating Field, with no modulation applied, with frequency $f_{s,c}$ (nominal value). The signal generator level is set so that the voltage $V_{GEN,J2,MAX10}$ is observed at the J2 output of the Reference Poller-0 for a time t_{MAX} .
 - The signal generator level is switched off (0 V observed at the J2) of the Reference Poller-0 for a time t_{OFF} .

- The following two steps are repeated continuously for the duration of t_{MAX} :
 - The signal generator level is adjusted to reach $V_{GEN,J2,MAX12}$. observed at the J2 output of the Reference Poller-0 for a time t_{MAX12} .
 - The signal generator level is switched off (0 V, observed at the J2 output of the Reference Poller-0) for a time t_{OFF} .
- A cool down guard time equal to t_{GT} SHALL be observed before checking the requirement below.
- Refer to Appendix B.3 for the values of t_{MAX12} , t_{OFF} , t_{GT} and t_{MAX} .

Requirements 4.12 —Excessive field strength Exposure (Listener Sustainability)

Listener

4.12.2.1 A Listener SHALL function properly within the Operating Volume of the Reference Poller after the Excessive field strength exposure conditions have been established as described in the specification context above for all supported technologies.
See Section 3.5 for the definition of “function properly”.

5 Signal Interface Poller to Listener

This section specifies the modulation methods used by NFC-A, NFC-B, NFC-F and NFC-V for communication from the Poller to the Listener. It deals with:

- The data transmission characteristics of the Poller, given as requirements listed in Sections 5.1, 5.3, 5.5 and 5.7.
- The reception capabilities of the Listener to interpret the data transmission of the Poller, given as requirements listed in Section 5.2, 5.4 and 5.6.

The DIGITAL specification defines four possible modulation types, called NFC-A, NFC-B, NFC-F and NFC-V, for communication from Poller to Listener. All four types use Amplitude Shift Keying (ASK).

The amplitude of the carrier is switched between V_1 and V_2 , creating a lower level when the field is at value V_2 . The requirements of the lower level, V_2 , as well as the envelope or wave shape of the carrier for the four modulation types, are defined in the following sections.

All specifications described in this section are characterized in conjunction with the Reference Poller and the Reference Listeners being set up and calibrated as specified in the appendices of this document.

The following requirements SHALL apply within the whole Operating Volume.

5.1 Poller Requirements for Modulation Poller to Listener – NFC-A

NFC-A communication from Poller to Listener uses the modulation principle of ASK, nominally 100%. The carrier is turned on and off, creating a lower level when turned off. In practice, it will result in a modulation depth of 95% or higher. The lower level for NFC-A modulation is referred to as “pause” by [ISO/IEC_14443] and NFCIP-1.

5.1.1 Specification Purpose

The purpose of these requirements is to ensure that a Poller produces NFC-A modulation characteristics that are within a Listener’s receiver capability so that the Poller’s transmission can be reliably received by any Listener.

5.1.2 Specification Context

- The Reference Listener is configured with the settings for the fixed resistive load and resonance frequency (see R_L and f_{RES} for “Modulation Poller→Listener (NFC-A)” in Appendix B.2) and no modulation transmit signal is applied to J2.
- The Poller is configured to send an ALL_REQ or SENS_REQ command.
- The Reference Listener is placed in the Operating Volume of the Poller.
- An ALL_REQ or SENS_REQ signal transmitted by the Poller is received and characterized at the output of the 8-Shaped Coil, as described in Appendix C.

In this section the symbol V represents the envelope of the signal monitored at the output of the 8-Shaped Coil (described in Appendix C) when the Reference Listener is placed in the Operating Volume of the Poller.

V_1 is the initial value measured immediately before the first modulation is applied by the Poller.
 V_2 , V_3 and V_4 are defined as follows:

$$V_2 = 0.05V_1$$

$$V_3 = 0.6V_1$$

$$V_4 = 0.9V_1 .$$

The falling edge is that part of the envelope V in which V decreases from V_4 to V_2 . The rising edge is that part of the envelope V in which V increases from V_2 to V_4 .

Figure 8 shows a representation of the wave shape and position of parameters.

Requirements 5.1 — Modulation Poller to Listener – NFC-A (Poller Transmission)

Poller	
	When measured as described in the specification context above, the Poller SHALL modulate the Operating Field in the Operating Volume in such a way that the signal monitored at the output of the 8-Shaped Coil (described in Appendix C) has the following characteristics:
5.1.2.1	The time between V_4 of the falling edge and V_2 of the rising edge SHALL be $t_{1,A}$.
5.1.2.2	If V does not decrease monotonically with time from V_4 to V_2 , the time between a local maximum and the time of passing the same value before the local maximum SHALL be $t_{5,A}$. This SHALL only apply if the local maximum is greater than V_2 .
5.1.2.3	Ringings following the falling edge SHALL remain below $V_{OU,A} \times V_1$.
5.1.2.4	V SHALL remain less than V_2 for a time $t_{2,A}$.
5.1.2.5	V SHALL increase monotonically with time from V_2 to V_3 in a time $t_{4,A}$.
5.1.2.6	V SHALL increase monotonically with time from V_2 to V_4 in a time $t_{3,A}$.
5.1.2.7	Overshoots immediately following the rising edge SHALL remain within the range $(1 \pm V_{OU,A}) \times V_1$.
	Refer to Appendix B.2 for the values of $t_{1,A}$, $t_{2,A}$, $t_{3,A}$, $t_{4,A}$, $t_{5,A}$ and $V_{OU,A}$.

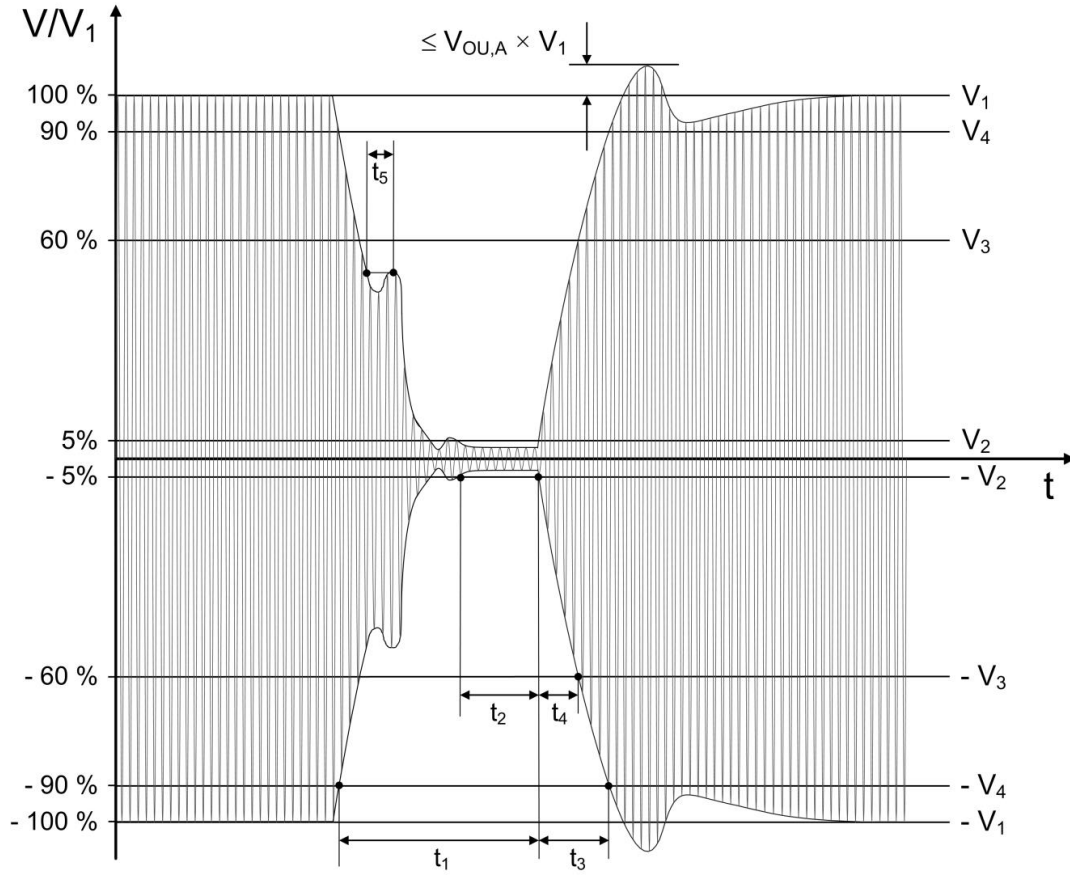

Figure 8: Modulation Poller to Listener for NFC-A

5.2 Listener Requirements for Modulation Poller to Listener – NFC-A

This section lists the requirements for the reception capabilities of a Listener of NFC-A.

5.2.1 Specification Purpose

The purpose of these requirements is to ensure that a Listener functions properly with a Reference Poller that applies NFC-A modulation characteristics at the border of the tolerance interval.

5.2.2 Specification Context

- A Reference Poller is set for nominal power, as specified in Appendix B.7.
- A Reference Listener is configured with fixed resistive load and resonance frequency (see $R_{S,L}$ and $f_{S,RES}$ for “Modulation Poller→Listener (NFC-A)” in Appendix B.3) and no modulation transmit signal is applied to J2.”
- A Poller is configured to send an ALL_REQ or SENS_REQ command.
- With the Reference Listener placed in the Operating Volume of the Reference Poller, the modulation characteristics of the ALL_REQ or SENS_REQ signal transmitted by the Poller are adjusted to obtain modulation characteristics $t_{S,1,A}$, $t_{S,2,A}$, $t_{S,3,A}$, $t_{S,4,A}$ and $V_{S,OU,A}$. The modulation characteristics are monitored at the output of the 8-Shaped Coil. Refer to Appendix B.3 for the setup values of $t_{S,1,A}$, $t_{S,2,A}$, $t_{S,3,A}$, $t_{S,4,A}$ and $V_{S,OU,A}$.
- The Listener is placed in Operating Volume of the Reference Poller.

Requirements 5.2 — Modulation Poller to Listener – NFC-A (Listener Reception)

Listener	
5.2.2.1	When it is placed in the Operating Volume of the Reference Poller, a Listener of NFC-A SHALL function properly when the Reference Poller has been set up as described in the specification context above.

5.3 Poller Requirements for Modulation Poller to Listener – NFC-B

NFC-B communication from Poller to Listener uses the modulation principle of ASK, nominally 10%.

The amplitude of the carrier is reduced to create a lower level with a modulation index m_i .

The requirements on the lower level as well as on the envelope of the carrier are defined below.

When analog levels are used to derive digital timing characteristics:

- The rise time is considered to be part of the unmodulated section and is excluded from the period when the modulation is applied.
- The fall time is considered to be part of the modulated section and is excluded from the period when the modulation is not applied.

5.3.1 Specification Purpose

The purpose of these requirements is to ensure that a Poller produces NFC-B modulation characteristics that are within a Listener’s receiver capability, so that the Poller’s transmission can be reliably received by the Listener.

It is not the purpose of this section to define requirements on bit boundaries; those are defined in DIGITAL.

5.3.2 Specification Context

- A Reference Listener is configured with the settings for the fixed resistive load and resonance frequency (see R_L and f_{RES} for “Modulation Poller→Listener (NFC-B)” in Appendix B.2), and no modulation transmit signal is applied to J2.
- A Poller is configured to send either an ALLB_REQ command or a SENSB_REQ command.
- The Reference Listener is placed in the Operating Volume of the Poller.
- The ALLB_REQ or SENSB_REQ signal transmitted by the Poller is received and characterized at the output of the 8-Shaped Coil, as described in Appendix C.

In this section the symbol V represents the envelope of the signal measured at the output of the 8-Shaped Coil (described in Appendix C), with the Reference Listener placed in the Operating Volume of the Poller.

V_a is the initial value measured immediately before the first modulation is applied by the Poller.

V_b is the lower level. The modulation index (m_i), V_3 and V_4 are defined as follows:

$$m_i = \frac{V_a - V_b}{V_a + V_b}$$

$$V_3 = V_a - 0.1(V_a - V_b)$$

$$V_4 = V_b + 0.1(V_a - V_b)$$

Figure 9 is a representation of the wave shape and position of parameters.

Requirements 5.3 — Modulation Poller to Listener – NFC-B (Poller Transmission)

Poller

When measured as described in the specification context above, the Poller SHALL modulate the Operating Field in the Operating Volume in such a way that the signal measured at the output of the 8-Shaped Coil (described in Appendix C) has the following characteristics:

- 5.3.2.1 The modulation index (m_i) of the signal SHALL be $\text{mod}_{i,B}$.
- 5.3.2.2 V SHALL decrease from V_3 to V_4 (i.e., the falling edge) in a time $t_{f,B}$.
- 5.3.2.3 V SHALL increase from V_4 to V_3 (i.e., the rising edge) in a time $t_{r,B}$.
- 5.3.2.4 The rising and falling edges of the modulation SHALL be monotonic with time.
- 5.3.2.5 Overshoots and undershoots following the falling edge (h_f) SHALL be less than $V_{OU,B} \times (V_a - V_b)$.
- 5.3.2.6 Overshoots and undershoots following the rising edge (h_r) SHALL be less than $V_{OU,B} \times (V_a - V_b)$.

Refer to Appendix B.2 for the values of $\text{mod}_{i,B}$, $t_{f,B}$, $t_{r,B}$ and $V_{OU,B}$.

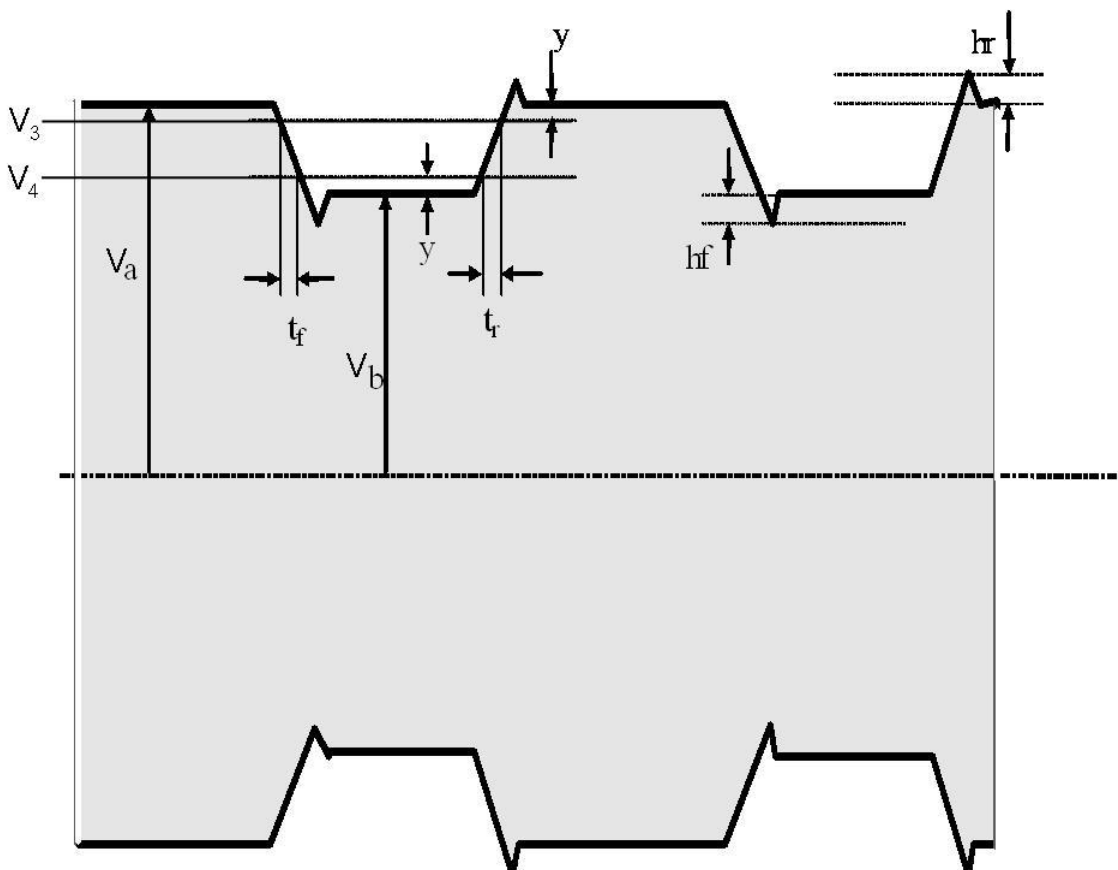

Figure 9: Modulation Poller to Listener for NFC-B

5.4 Listener Requirements for Modulation Poller to Listener – NFC-B

This section lists the requirements for the reception capabilities of a Listener of NFC-B.

When analog levels are used to derive digital timing characteristics:

- The rise time is considered to be part of the unmodulated section and is excluded from the period when the modulation is applied.
- The fall time is considered to be part of the modulated section and is excluded from the period when the modulation is not applied.

5.4.1 Specification Purpose

The purpose of these requirements is to ensure that a Listener functions properly with the Reference Poller that applies NFC-B modulation characteristics at the border of the tolerance interval.

5.4.2 Specification Context

- A Reference Poller is set for nominal power, as specified in Appendix B.7.
- A Reference Listener is configured with fixed resistive load and resonance frequency (see $R_{s,L}$ and $f_{s,RES}$ for “Modulation Poller→Listener (NFC-B)” in Appendix B.3) and no modulation transmit signal is applied to J2.
- A Poller is configured to send an ALLB_REQ or SENSB_REQ command.
- With the Reference Listener placed in the Operating Volume of the Reference Poller, the modulation characteristics of the ALLB_REQ or SENSB_REQ signal transmitted by the Poller are adjusted to obtain modulation characteristics $m_{s,i,B}$, $t_{s,f,B}$, $t_{s,r,B}$ and $V_{s,ou,B}$. The modulation characteristics are monitored at the output of the 8-Shaped Coil. Refer to Appendix B.3 or the setup values of $m_{s,i,B}$, $t_{s,f,B}$, $t_{s,r,B}$ and $V_{s,ou,B}$.
- The Listener is placed in the Operating Volume of the Reference Poller.

Requirements 5.4 — Modulation Poller to Listener – NFC-B (Listener Reception)

Listener

- 5.4.2.1** When it is placed in the Operating Volume of the Reference Poller, a Listener of NFC-B SHALL function properly when the Reference Poller has been set up as described in the specification context above.

5.5 Poller Requirements for Modulation Poller to Listener – NFC-F

NFC-F communication from Poller to Listener uses the modulation principle of ASK, nominally 10%.

The amplitude of the carrier is reduced to create a lower level with a modulation index m_i . The requirements on the lower level, as well as on the envelope of the carrier, are defined below.

When analog levels are used to derive digital timing characteristics:

- The rise time is considered to be part of the unmodulated section and is excluded from the period when the modulation is applied.
- The fall time is considered to be part of the modulated section and is excluded from the period when the modulation is not applied.

5.5.1 Specification Purpose

The purpose of these requirements is to ensure that a Poller produces NFC-F modulation characteristics that are within a Listener’s receiver capability, so that the Poller’s transmission can be reliably received by the Listener.

It is not the purpose of this section to define requirements on bit boundaries; those are defined in DIGITAL.

5.5.2 Specification Context

- A Reference Listener is configured with the settings for the fixed resistive load and resonance frequency (see R_L and f_{RES} for “Modulation Poller→Listener (NFC-F)” in Appendix B.2) and no modulation transmit signal is applied to J2.
- The Poller is configured to send a SENSF_REQ command.
- The Reference Listener is placed in the Operating Volume of the Poller.
- A SENSF_REQ signal transmitted by the Poller is received and characterized at the output of the sense coil of the 8-Shaped Coil, as described in Appendix C.

In this section the symbol V represents the envelope of the signal measured at the output of the 8-Shaped Coil (described in Appendix C) with the Reference Listener placed in the Operating Volume of the Poller.

V_a is the initial value measured immediately before any modulation is applied by the Poller. V_b is the lower level. The modulation index (m_i), V_3 and V_4 are defined as follows:

$$m_i = \frac{V_a - V_b}{V_a + V_b}$$

$$V_3 = V_a - 0.1(V_a - V_b)$$

$$V_4 = V_b + 0.1(V_a - V_b)$$

Figure 10 shows a representation of the wave shape and position of parameters.

Requirements 5.5 — Modulation Poller to Listener – NFC-F (Poller Transmission)

Poller

When measured as described in the specification context above, the Poller SHALL modulate the Operating Field in the Operating Volume in such a way that the signal measured at the output of the 8-Shaped Coil (described in Appendix C) has the following characteristics:

- 5.5.2.1 The modulation index (m_i) of the signal SHALL be $\mathbf{mod}_{i,F}$.
- 5.5.2.2 V SHALL decrease from \mathbf{V}_3 to \mathbf{V}_4 (i.e., the falling edge) in a time $\mathbf{t}_{f,F}$.
- 5.5.2.3 V SHALL increase from \mathbf{V}_4 to \mathbf{V}_3 (i.e., the rising edge) in a time $\mathbf{t}_{r,F}$.
- 5.5.2.4 The rising and falling edges of the modulation SHALL be monotonic with time.
- 5.5.2.5 Overshoots and undershoots following the falling edge (\mathbf{h}_f) SHALL be less than $\mathbf{V}_{OU,F} \times (\mathbf{V}_a - \mathbf{V}_b)$.
- 5.5.2.6 Overshoots and undershoots following the rising edge (\mathbf{h}_r) SHALL be less than $\mathbf{V}_{OU,F} \times (\mathbf{V}_a - \mathbf{V}_b)$.

Refer to Appendix B.2 for the values of $\mathbf{mod}_{i,F}$, $\mathbf{t}_{f,F}$, $\mathbf{t}_{r,F}$ and $\mathbf{V}_{OU,F}$.

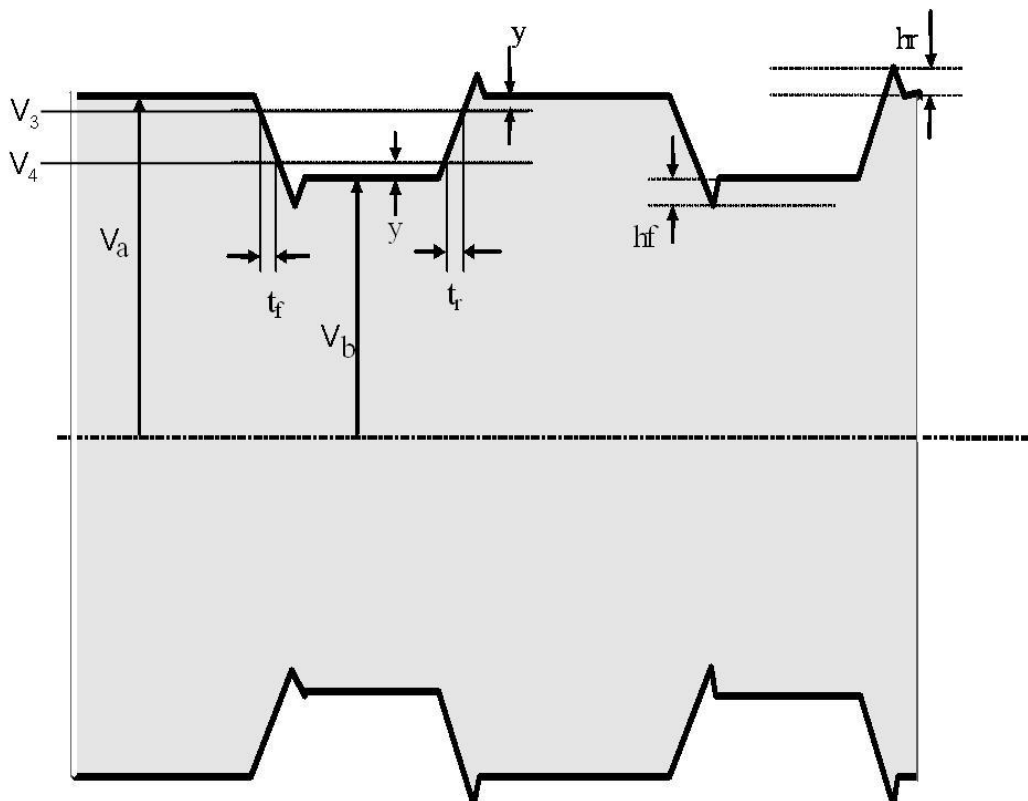

Figure 10: Modulation Poller to Listener for NFC-F

5.6 Listener Requirements for Modulation Poller to Listener – NFC-F

This section lists the requirements for the reception capabilities of a Listener of NFC-F.

5.6.1 Specification Purpose

The purpose of these requirements is to ensure that a Listener functions properly with a Reference Poller that applies NFC-F modulation characteristics at the border of the tolerance interval.

When analog levels are used to derive digital timing characteristics:

- The rise time is considered to be part of the unmodulated section and is excluded from the period when the modulation is applied.
- The fall time is considered to be part of the modulated section and is excluded from the period when the modulation is not applied.

5.6.2 Specification Context

- A Reference Poller is set for nominal power as specified in Appendix B.7.
- A Reference Listener is configured with fixed resistive load resonance frequency (see $R_{S,L}$ and $f_{S,RES}$ for “Modulation Poller→Listener (NFC-F)” in Appendix B.3), and no modulation transmit signal is applied to J2.
- The Poller is configured to send an SENSE_REQ command.
- With the Reference Listener placed in the Operating Volume of the Reference Poller, the modulation characteristics of the SENSE_REQ signal transmitted by the Poller are adjusted to obtain modulation characteristics $m_{S,i,F}$, $t_{S,f,F}$, $t_{S,r,F}$ and $V_{S,OU,F}$. The modulation characteristics are monitored at the output of the 8-Shaped Coil. Refer to Appendix B.3 for the setup values of $m_{S,i,F}$, $t_{S,f,F}$, $t_{S,r,F}$ and $V_{S,OU,F}$.
- The Listener is placed in the Operating Volume of the Reference Poller.

Requirements 5.6 — Modulation Poller to Listener – NFC-F (Listener Reception)

Listener	
5.6.2.1	When placed in the Operating Volume of the Reference Poller, a Listener of NFC-F SHALL function properly for each bit rate supported by the device when the Reference Poller has been set up as described in the specification context above.

5.7 Poller Requirements for Modulation Poller to Listener – NFC-V

NFC-V communication from Poller to Listener uses the modulation principle of ASK, nominally 100%. The carrier is turned on and off, creating a lower level when turned off. In practice, it will result in a modulation depth of 95% or higher. The lower level for NFC-V modulation is referred to as “pause” by [ISO/IEC_15693]

5.7.1 Specification Purpose

The purpose of these requirements is to ensure that a Poller produces NFC-V modulation characteristics that are within a Listener’s receiver capability, so that the Poller’s transmission can be reliably received by any NFC Forum Tag Type 5.

5.7.2 Specification Context

- A Reference Listener is configured with the settings for the fixed resistive load and resonance frequency (see R_L and f_{RES} for “Modulation Poller→Listener (NFC-V)” in Appendix B.2), and no modulation transmit signal is applied to J2.
- A Poller is configured to send an INVENTORY_REQ command.
- The Reference Listener is placed in the Operating Volume of the Poller.
- An INVENTORY_REQ signal transmitted by the Poller is received and characterized at the output of the 8-Shaped Coil, as described in Appendix C.

In this section the symbol V represents the envelope of the signal monitored at the output of the 8-Shaped Coil(described in Appendix C) with the Reference Listener placed in the Operating Volume of the Poller.

V_1 is the initial value measured immediately before the first modulation is applied by the Poller.

V_2 , V_3 and V_4 are defined as follows:

$$V_2 = 0.05V_1$$

$$V_3 = 0.6V_1$$

$$V_4 = 0.95V_1 .$$

The falling edge is that part of the envelope V , where V decreases from V_4 to V_2 . The rising edge is that part of the envelope V , where V increases from V_2 to V_4 .

Figure 11 shows a representation of the wave shape and position of parameters.

Requirements 5.7 — Modulation Poller to Listener – NFC-V (Poller Transmission)

Poller

When it is measured as described in the specification context above, the Poller SHALL modulate the Operating Field in the Operating Volume in such a way that the signal monitored at the output of the 8-Shaped Coil (described in Appendix C) has the following characteristics:

- 5.7.2.1 The time between V_4 of the falling edge and V_2 of the rising edge SHALL be $t_{1,v}$.
- 5.7.2.2 If V does not decrease monotonically with time from V_4 to V_2 , the time between a local maximum and the time of passing the same value before the local maximum SHALL be t_5 . This SHALL only apply if the local maximum is greater than V_2 .
- 5.7.2.3 Ringing following the falling edge SHALL remain below $V_{ou,v} \times V_1$.
- 5.7.2.4 V SHALL remain less than V_2 for the length of time $t_{2,v}$.
- 5.7.2.5 V SHALL increase monotonically with time from V_2 to V_3 in the time period $t_{4,v}$.
- 5.7.2.6 V SHALL increase monotonically with time from V_2 to V_4 in the time period $t_{3,v}$.
- 5.7.2.7 Overshoots immediately following the rising edge SHALL remain within $(1 \pm V_{ou,v}) \times V_1$.

Refer to Appendix B.2 for the values of $t_{1,v}$, $t_{2,v}$, $t_{3,v}$, $t_{4,v}$, $t_{5,v}$ and $V_{ou,v}$.

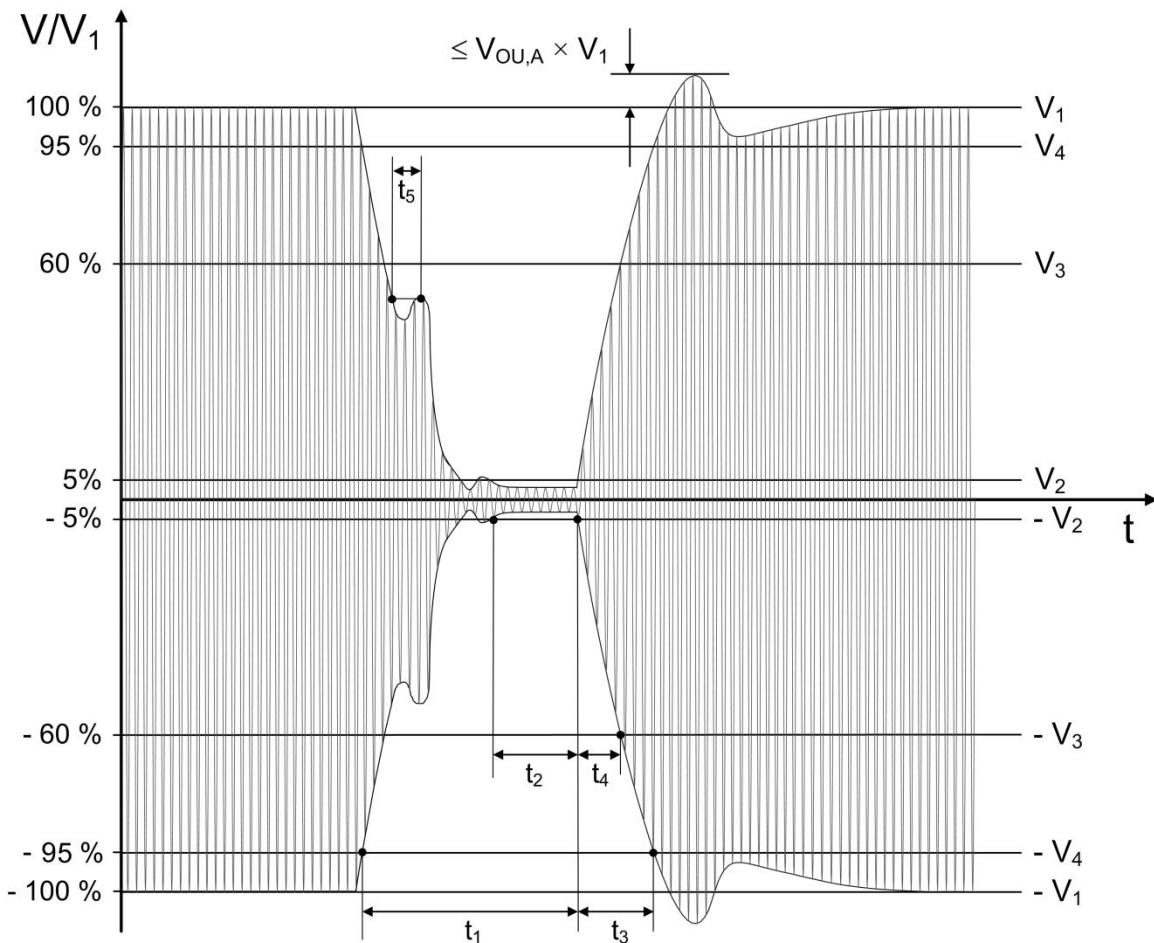

Figure 11: Modulation Poller to Listener for NFC-V

5.8 Listener Requirements for Modulation Poller to Listener – NFC-V

This section lists the requirements for the reception capabilities of a Listener of NFC-V.

5.8.1 Specification Purpose

The purpose of these requirements is to ensure that a Listener functions properly with a Reference Poller that applies NFC-V modulation characteristics at the border of the tolerance interval.

5.8.2 Specification Context

- The Reference Poller is set for nominal power as specified in Appendix B.7.
- The Reference Listener is configured with fixed resistive load (see $R_{S,L}$ for “Modulation Poller→Listener (NFC-V)” in Appendix B.3) and no modulation transmit signal is applied to J_2 .
- Poller configured to send an INVENTORY_REQ command.

- With the Reference Listener placed in the Operating Volume of the Reference Poller, the modulation characteristics of the INVENTORY_REQ signal transmitted by the Poller are adjusted to obtain modulation characteristics $t_{s,1,v}$, $t_{s,2,v}$, $t_{s,3,v}$, $t_{s,4,v}$ and $V_{s,ou,v}$. The modulation characteristics are monitored at the output of 8-Shaped Coil. Refer to Appendix B.3 for the setup values of $t_{s,1,v}$, $t_{s,2,v}$, $t_{s,3,v}$, $t_{s,4,v}$ and $V_{s,ou,v}$.
- The Listener is placed in Operating Volume of the Reference Poller.

Requirements 5.8 — Modulation Poller to Listener – NFC-V (Listener Reception)**Listener**

- 5.8.2.1** When placed in the Operating Volume of the Reference Poller, a Listener of NFC-V SHALL function properly when the Reference Poller has been set up as described in the specification context above.

6 Signal Interface Listener to Poller

This section specifies the modulation methods used by NFC-A, NFC-B, NFC-F and NFC-V for the communication from a Listener to a Poller. The section deals with:

- The data transmission characteristics of the Listener, given as requirements listed in sections 6.1, 6.2, 6.3, 6.4 and 6.5.
- The reception capabilities of the Poller to interpret the data transmission of the Listener, given as requirements listed in section 6.6.

For the communication from the Listener to the Poller, the NFC-A, NFC-B, NFC-F and NFC-V use load modulation, as shown in Figure 12. The NFC Forum device generates the Load Modulation signal for NFC-A, NFC-B, NFC-F and NFC-V, either by switching a load or by any other means that generates (in accordance with this specification) the Load Modulation signal over the air interface.

For NFC-A and NFC-B the carrier frequency f_c is used to derive a subcarrier with frequency f_s equal to $f_c/16$ (~847 kHz). Applying the load modulation at this frequency creates the subcarrier.

For NFC-F the load modulation is applied with a 50% duty cycle. When the Listener is in the loaded state, a higher current will flow through the antenna of the Listener than when the load modulation is not switched on.

For NFC-V the carrier frequency f_c is used to derive a subcarrier with frequency f_s equal to $f_c/32$ (~423.75 kHz). Applying the load modulation at this frequency creates the subcarrier.

This difference in current in the Listener antenna is sensed by the Poller.

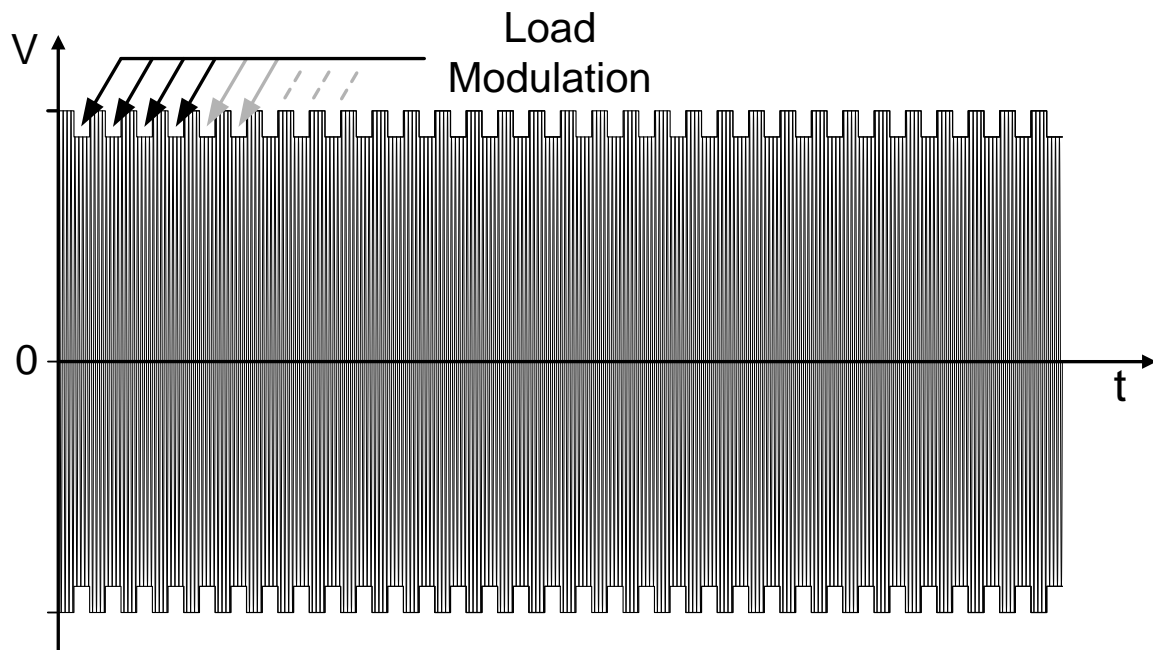

Figure 12: Load Modulation Listener to Poller

NFC-A modulates a subcarrier using On-Off Keying (OOK). Symbols are described in DIGITAL.

NFC-B modulates a subcarrier using Binary Phase Shift Keying (BPSK). Symbols are described in DIGITAL.

For NFC-F the load modulation scheme is the same as the one used for the communications from the Poller to the Listener. Refer to Section 5.5 for details. Symbols are described in DIGITAL.

NFC-V modulates a subcarrier using On-Off Keying (OOK). Symbols are described in DIGITAL.

All requirements described in this section SHALL be evaluated with the Reference Poller and the Reference Listener, each calibrated as specified in the specification context of the requirement.

6.1 Listener Requirements for Load Modulation Generic

This section lists for the Listener the load modulation generation requirements that are the same for all NFC-A, NFC-B, NFC-F and NFC-V.

6.1.1 Specification Purpose

The purpose of these requirements is to ensure that the Listener produces load modulation that is compatible with the modulation expected by the Poller's receiver and has sufficient amplitude to ensure that it can be received successfully.

6.1.2 Specification Context

- A Reference Poller is set up for nominal and maximum power, as specified in Appendix B.7.
- The Reference Poller is set up for nominal modulation characteristics, as specified in Appendix B.7.
- The Reference Poller sends an ALL_REQ or SENS_REQ command to a Listener for NFC-A, or an ALLB_REQ or SENSB_REQ command to a Listener for NFC-B, or an SENSF_REQ command to a Listener for NFC-F, or an INVENTORY_REQ command to a Listener for NFC-V.
- A Listener is placed in the Operating Volume of the Reference Poller.

Requirements 6.1 — Load Modulation Characteristics - Generic (Listener Transmission)

Listener	
	When it is placed in the Operating Volume of the Reference Poller that has been set up as described in the specification context above, the Listener SHALL modulate the Operating Field in such a way that the signal monitored at J2 of the Reference Poller has the following characteristics:
6.1.2.1	The subcarrier frequency f_s of the modulation signal SHALL be $f_c / 16$ for NFC-A and NFC-B.
6.1.2.2	For NFC-F the frequency f_s of the modulation signal during the preamble SHALL be $f_c / 32$ or $f_c / 64$.
6.1.2.3	The subcarrier frequency f_s of the modulation signal SHALL be $f_c / 32$ for NFC-V
6.1.2.4	The average amplitude of the two sidebands ($f_c + f_s$ and $f_c - f_s$), calculated from the modulation signal at J2 of the Reference Poller using the DFT method, SHALL be V_{LMA} .
	(Choosing a measurement position that avoids all transient effects, e.g., the first change from 0 to 1 for NFC-A, the TR1 zone for NFC-B and NFC-F, and the pattern I for NFC-V, as defined in DIGITAL.)
	Refer to Appendix B.2 for the value of V_{LMA} and to Appendix B.4 for the definition of antenna category.

6.2 Listener Requirements for Subcarrier Load Modulation NFC-A

This section lists the Listener requirements for the modulation of the subcarrier for communication from the Listener to the Poller for NFC-A.

6.2.1 Specification Purpose

The purpose of these requirements is to ensure that the Listener produces load modulation that is compatible with the modulation expected by the Poller’s receiver.

Requirements 6.2 — Load Modulation Characteristics – NFC-A (Listener Transmission)

Listener	
6.2.1.1	A Listener of NFC-A SHALL modulate the subcarrier using On-Off Keying (OOK).
6.2.1.2	When it is modulating the subcarrier, the Listener of NFC-A SHALL only start the bit period on the rising or falling edge of the subcarrier, so that the modulation starts with a defined phase relationship to the subcarrier.

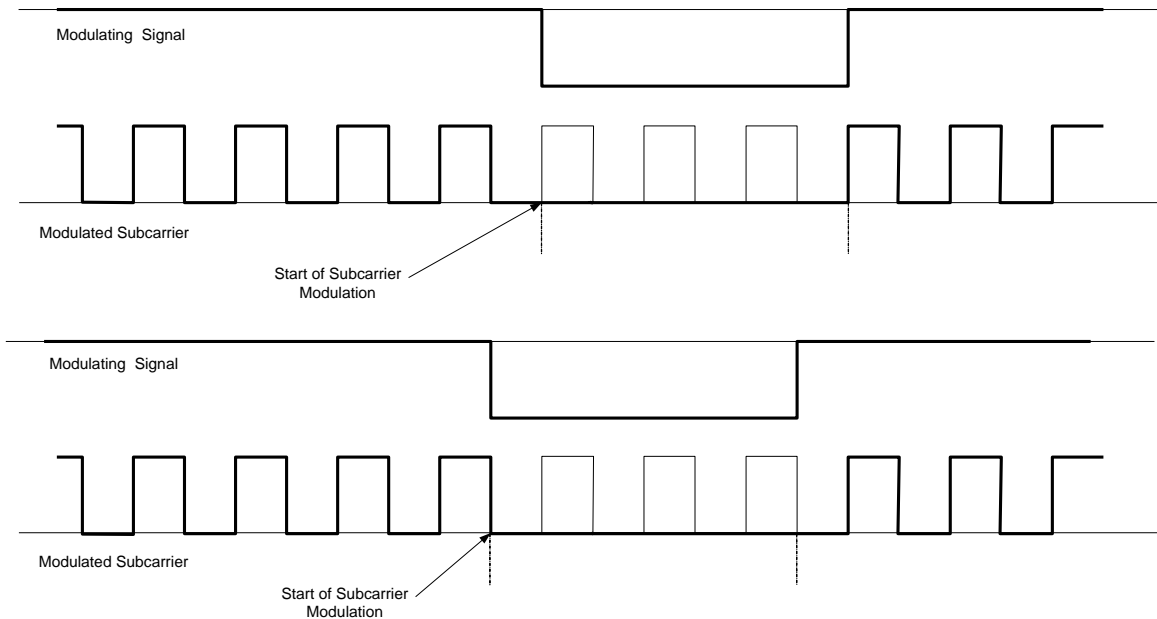

Figure 13: Start of Subcarrier Modulation – NFC-A

6.3 Listener Requirements for Subcarrier Load Modulation NFC-B

A Listener of NFC-B modulates the subcarrier using BPSK. Before the Listener sends information to the Poller by means of phase shifts, the Listener and Poller first establish a reference phase $\emptyset 0$. Then the Listener can start modulating the subcarrier: a change of logic level is denoted by a phase shift of 180° of the subcarrier.

6.3.1 Specification Purpose

The purpose of these requirements is to ensure that the Listener produces load modulation that is compatible with the modulation expected by the Poller’s receiver.

Requirements 6.3 — Load Modulation Characteristics – NFC-B (Listener Transmission)

Listener	
6.3.1.1	A Listener of NFC-B SHALL modulate the subcarrier using BPSK.
6.3.1.2	The Listener of NFC-B SHALL generate a subcarrier only when data are to be transmitted.
6.3.1.3	Phase shifts SHALL only occur at nominal positions of the rising or falling edges of the subcarrier.

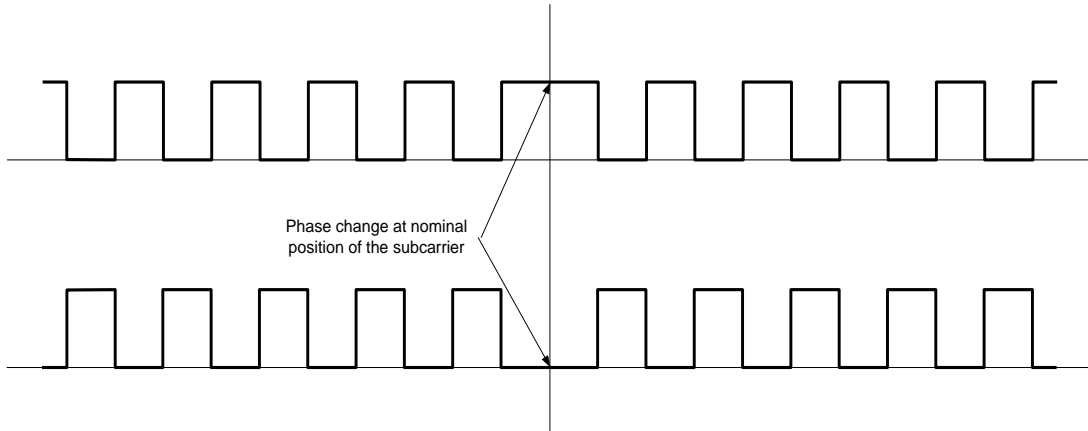

Figure 14: Allowed Phase Shifts – NFC-B

6.4 Listener Requirements for Load Modulation NFC-F

A Listener of NFC-F modulates the carrier using ASK.

6.4.1 Specification Purpose

The purpose of these requirements is to ensure that the Listener produces load modulation that is compatible with the modulation expected by the Poller’s receiver.

It is not the purpose of this section to define requirements on bit boundaries; those are defined in DIGITAL.

Requirements 6.4 — Load Modulation Characteristics – NFC-F (Listener Transmission)

Listener

6.4.1.1 A Listener of NFC-F SHALL load modulate the carrier using Amplitude Shift Keying (ASK).

6.5 Listener Requirements for Subcarrier Load Modulation NFC-V

This section lists the Listener requirements for the modulation of the subcarrier for the communication from the Listener to the Poller for NFC-V.

6.5.1 Specification Purpose

The purpose of these requirements is to ensure that the Listener produces load modulation that is compatible with the modulation expected by the Poller’s receiver.

Requirements 6.5 — Load Modulation Characteristics – NFC-V (Listener Transmission)

Listener

6.5.1.1 A Listener of NFC-V SHALL modulate the subcarrier using On-Off Keying (OOK).

6.5.1.2 When it is modulating the subcarrier, the Listener of NFC-V SHALL only start the bit period on the rising or falling edge of the subcarrier, so that the modulation starts with a defined phase relationship to the subcarrier.

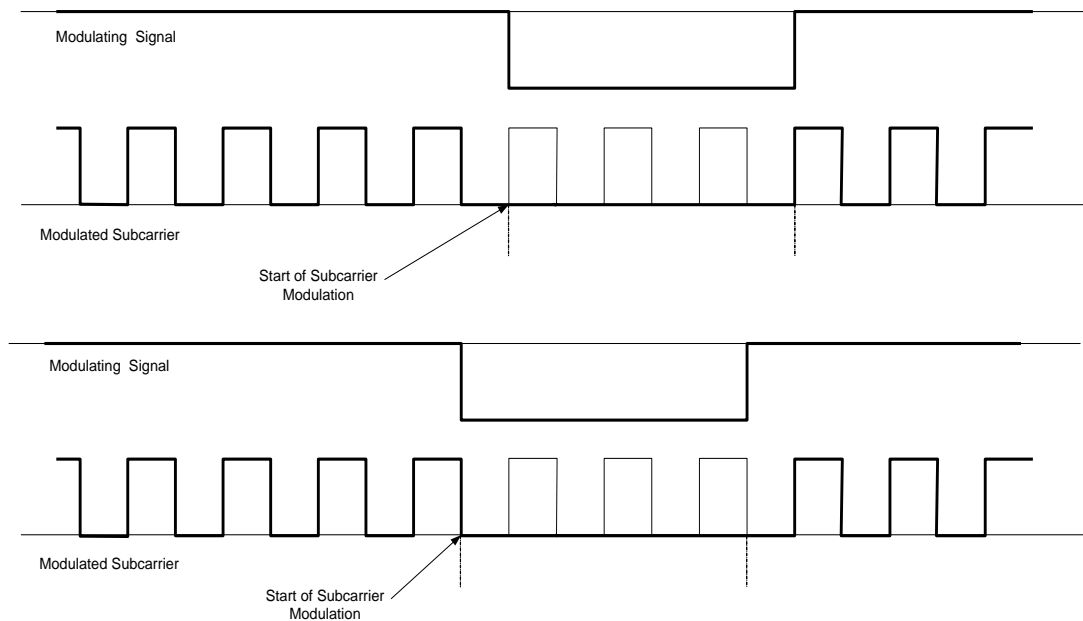

Figure 15: Start of Subcarrier Modulation – NFC-V

6.6 Poller Requirements for Load Modulation Listener to Poller

This section lists the requirements for the reception capabilities of a Poller to interpret the modulation applied by the Listener at the border of the tolerance interval.

6.6.1 Specification Purpose

The purpose of these requirements is to ensure that the receiver in the Poller is able to receive the load modulation amplitude range produced by a Listener.

6.6.2 Specification Context

Power Setup:

- A Poller is set to emit an Operating Field with no modulation – Operating Field On.
- A Reference Listener is configured with a resistive load (see $R_{S,L}$ for “Power transfer: Poller→Listener $V_{S,OV,MIN}$ ” in Appendix B.3). See Appendix C.4 for design details.
- Measure V_{OV} with the Reference Listener placed in the operating volume of the Poller.
- A Reference Poller is set to the minimum V_{OV} for $V_{S,LMA,MIN}$ and to the maximum V_{OV} for $V_{S,LMA,MAX}$, as measured in the previous step, with the respective Reference Listener (used in the next steps) in position ($z=Z_{S,LM}$, $r=0$, $\varphi=0$, $\theta=0$) of the Operating Volume of the Reference Poller.

Load Modulation Setup:

- A Reference Listener is configured with the settings for the fixed resistive load and resonance frequency (see $R_{S,L}$ and $f_{S,RES}$ for “Load Modulation (NFC-A, NFC-B, NFC-F, NFC-V)” in Appendix B.3).
- A Reference Listener is set to produce an appropriate response with load modulation of an amplitude $V_{S,LMA}$ (peak), calculated as the average of the two sidebands ($f_c + f_s$ and $f_c - f_s$) obtained by applying the DFT method on the modulation signal.
- The response is captured at J2 of the Reference Poller, when it is placed in the position ($z=Z_{S,LM}$, $r=0$, $\varphi=0$, $\theta=0$) of the Operating Volume of the Reference Poller. Refer to Appendix B.3 for the values of $Z_{S,LM}$ and $V_{S,LMA}$.

Test Procedure:

- Set the Poller to send a valid command to the Reference Listener.

Requirements 6.6 — Modulation Listener to Poller (Poller Reception)

Poller	
6.6.2.1	For NFC-A, NFC-B, NFC-F and NFC-V, the Poller SHALL function properly with the Reference Listener placed in its Operating Volume, provided the Reference Listener has been set up as described in the specification context above.

A. Exhibit A

Exhibit A includes:

- C. Design Information for NFC Forum Reference Equipment and 8-Shaped Coil.

B. Parameter Values

Throughout the main body of this technical specification, symbols are used to identify the values of parameters. The actual values of the parameters are listed in these appendices.

B.1 Operating Volume

This section lists the values of the parameters to define the Operating Volume.

Table 5: Parameters for Operating Volume

Topic	Parameter	Value	Units
Operating Volume	D1	10	mm
	D2	20	mm
	S1	5	mm

B.2 RF Power and Signal Interface

This section lists the values of the parameters that define the RF power and signal interface requirements. For each of the parameters a minimum and a maximum value are defined.

Unless stated otherwise, the Reference Listener is tuned to 13.56 MHz.

Table 6: Parameters for RF Power and Modulation

Topic	Parameter	Coil	Value		Unit s	R _L	f _{RES}
			Min	Max		Ω	MHz
Power transfer: Poller→Listener	V_{OV} 0 ≤ z ≤ S1	Listener-1	4.98		V	820	13.56
		Listener-3	4.68		V		
		Listener-6	4.04		V		
	V_{OV} 0 ≤ z ≤ S1	Listener-1		2.85	V	82	13.56
		Listener-3		2.30	V		
		Listener-6		2.23	V		
Influence of Listener	DVR	Poller-0	0	1		820	13.56
		Poller-3	0	1			
		Poller-6	0	1			
Carrier Frequency	f_C		13.553	13.567	MHz	820	13.56
Field Activation Time	t_{FIELD,ACT}		0	4 x t_{4,A,Max}	μs	820	13.56
Field Deactivation Time	t_{FIELD,DEACT}		0	t_{1,A,Max}	μs	820	13.56
Modulation Poller→Listener (NFC-A)	t_{1,A} (106 kbps)		2.06	2.99	μs	820	13.56 & 16.00
	t_{2,A} (106 kbps)		0.52	t_{1,A}	μs		
	t_{3,A} (106 kbps)		1.5 x t_{4,A}	1.18	μs		
	t_{4,A} (106 kbps)		0	0.44	μs		
	t_{5,A} (106 kbps)		0	0.50	μs		

Topic	Parameter	Coil	Value		Unit s	R _L	f _{RES}
			Min	Max		Ω	MHz
	V_{OU,A} (106 kbps)		0	$0 \leq t_3 \leq \frac{3}{f_c}$ $\Rightarrow \left(1 - \frac{t_3}{2 \cdot t_{3_max}}\right) \cdot 0.39$ $\frac{3}{f_c} \leq t_3 \leq \frac{6}{f_c}$ $\Rightarrow \frac{-y_1 + y_2}{3/f_c} \cdot t_3 + 2y_1 - y_2$ $\frac{6}{f_c} \leq t_3 \leq t_{3_max}$ $\Rightarrow \left(1 - \frac{t_3}{2 \cdot t_{3_max}}\right) \cdot 0.1$ with $y_1 = \left(1 - \frac{3/f_c}{2 \cdot t_{3_max}}\right) \cdot 0.39$ $y_2 = \left(1 - \frac{6/f_c}{2 \cdot t_{3_max}}\right) \cdot 0.1$	-	820	13.56 & 16.00
Modulation Poller→Listener (NFC-B)	mod_{i,B} (106 kbps)		8	15	%	820	13.56 & 16.00
	t_{f,B} (106 kbps)		0	1.18	μs		
	t_{r,B} (106 kbps)		Maximum of 0 and t_{f,B} -0.59	Minimum of 1.18 and 0.59+ t_{f,B}	μs		
	V_{OU,B} (106 kbps)		0	$0 \leq t_{r,B} \leq \frac{3}{f_c}$ $\Rightarrow \left(1 - \frac{t_{r,B}}{2 \cdot t_{r,B_max}}\right) \cdot 0.39$ $\frac{3}{f_c} \leq t_{r,B} \leq \frac{6}{f_c}$ $\Rightarrow \frac{-y_1 + y_2}{3/f_c} \cdot t_{r,B} + 2y_1 - y_2$ $\frac{6}{f_c} \leq t_{r,B} \leq t_{r,B_max}$ $\Rightarrow \left(1 - \frac{t_{r,B}}{2 \cdot t_{r,B_max}}\right) \cdot 0.1$ or	-	820	13.56 & 16.00

Topic	Parameter	Coil	Value		Units	R _L	f _{RES}
			Min	Max		Ω	MHz
				$0 \leq t_{f,B} \leq \frac{3}{f_c}$ $\Rightarrow \left(1 - \frac{t_{f,B}}{2 \cdot t_{f,B,max}}\right) \cdot 0.39$ $\frac{3}{f_c} \leq t_{f,B} \leq \frac{6}{f_c}$ $\Rightarrow \frac{-y_1 + y_2}{3/f_c} \cdot t_{f,B} + 2y_1 - y_2$ $\frac{6}{f_c} \leq t_{f,B} \leq t_{f,B,max}$ $\Rightarrow \left(1 - \frac{t_{f,B}}{2 \cdot t_{f,B,max}}\right) \cdot 0.1$ <p style="text-align: center;">with</p> $y_1 = \left(1 - \frac{3/f_c}{2 \cdot t_{f,B,max}}\right) \cdot 0.39$ $y_2 = \left(1 - \frac{6/f_c}{2 \cdot t_{f,B,max}}\right) \cdot 0.1$			
Modulation Poller→Listener (NFC-F)	mod_{i,F}		8	15	%	820	13.56 & 16.00
	t_{f,F} (212 kbps)		0	1.18	μs		
	t_{f,F} (424 kbps)		0	0.8	μs		
	t_{r,F} (212 kbps)		Maximum of 0 and t_{f,F} - 0.59	Minimum of 1.18 and 0.59+ t_{f,F}	μs		
	t_{r,F} (424 kbps)		Maximum of 0 and t_{f,F} -0.4	Minimum of 0.8 and 0.4+ t_{f,F}	μs		
	V_{OU,F}		0	$0 \leq t_{r,F} \leq \frac{3}{f_c}$ $\Rightarrow \left(1 - \frac{t_{r,F}}{2 \cdot t_{r,F,max}}\right) \cdot 0.39$ $\frac{3}{f_c} \leq t_{r,F} \leq \frac{6}{f_c}$ $\Rightarrow \frac{-y_1 + y_2}{3/f_c} \cdot t_{r,F} + 2y_1 - y_2$ $\frac{6}{f_c} \leq t_{r,F} \leq t_{r,F,max}$ $\Rightarrow \left(1 - \frac{t_{r,F}}{2 \cdot t_{r,F,max}}\right) \cdot 0.1$ <p style="text-align: center;">or</p> $0 \leq t_{f,F} \leq \frac{3}{f_c}$ $\Rightarrow \left(1 - \frac{t_{f,F}}{2 \cdot t_{f,F,max}}\right) \cdot 0.39$ $\frac{3}{f_c} \leq t_{f,F} \leq \frac{6}{f_c}$ $\Rightarrow \frac{-y_1 + y_2}{3/f_c} \cdot t_{f,F} + 2y_1 - y_2$ $\frac{6}{f_c} \leq t_{f,F} \leq t_{f,F,max}$ $\Rightarrow \left(1 - \frac{t_{f,F}}{2 \cdot t_{f,F,max}}\right) \cdot 0.1$ <p style="text-align: center;">with</p>	-	820	13.56 & 16.00

Topic	Parameter	Coil	Value		Unit s	R _L	f _{RES}
			Min	Max		Ω	MHz
				$y_1 = \left(1 - \frac{3/f_c}{2 \cdot t_{r/f,F_max}}\right) \cdot 0.39$ $y_2 = \left(1 - \frac{6/f_c}{2 \cdot t_{r/f,F_max}}\right) \cdot 0.1$			
Modulation Poller→Listener (NFC-V)	t_{1,v} (26 kbps)		6.03	9.41	μs	820	13.56 & 16.00
	t_{2,v} (26 kbps)		2.13	t_{1,v}	μs		
	t_{3,v} (26 kbps)		Greater of 1.5 x t_{4,v} or minimum achievable value	4.43	μs		
	t_{4,v} (26 kbps)		0	0.73	μs		
	t_{5,v} (26 kbps)		0	0.50	μs		
	V_{ou,v} (26 kbps)		0	$0 \leq t_3 \leq \frac{3}{f_c}$ $\Rightarrow \left(1 - \frac{t_3}{2 \cdot t_{3_max}}\right) \cdot 0.39$ $\frac{3}{f_c} \leq t_3 \leq \frac{6}{f_c}$ $\Rightarrow \frac{-y_1 + y_2}{3/f_c} \cdot t_3 + 2y_1 - y_2$ $\frac{6}{f_c} \leq t_3 \leq t_{3_max}$ $\Rightarrow \left(1 - \frac{t_3}{2 \cdot t_{3_max}}\right) \cdot 0.1$ <p style="text-align: center;">with</p> $y_1 = \left(1 - \frac{3/f_c}{2 \cdot t_{3_max}}\right) \cdot 0.39$ $y_2 = \left(1 - \frac{6/f_c}{2 \cdot t_{3_max}}\right) \cdot 0.1$	-	820	13.56 & 16.00

Topic	Parameter	Coil	Min		Max		RL Ω	Units
			Nom Power	Max Power	Nom Power	Max Power		
Load Modulation NFC Forum Tag Devices Poller←Listener	V_{LMA}	Poller-0	5.8		52.2			mVp
		Poller-3	2.8		32.0			mVp
		Poller-6	2		36.0			mVp
Load Modulation NFC Forum Devices in Listen Mode CAT C, Default Category Poller←Listener	V_{LMA}	Poller-0	12	8	52.2			mVp
		Poller-3	13	8	32.0			
		Poller-6	15	12	36.0			
Load Modulation NFC Forum Devices in Listen Mode CAT B: Poller←Listener	V_{LMA}	Poller-0	12	8	52.2			mVp
		Poller-3	8	5	32.0			
		Poller-6	8	6.5	36.0			
Load Modulation NFC Forum Devices in Listen Mode CAT A: Poller←Listener	V_{LMA}	Poller-0	9	7	52.2			mVp
		Poller-3	5	3	27.7			
		Poller-6	4	3.5	26.0			

NOTE In the above table the terms **tr,B_max**, **tr,F_max**, and **tf,F_max** refer to the absolute maximum values according to the max column of the associated rise/fall time definition, without **tr** versus **tf** symmetry limitations.

NOTE Refer to Appendix B.4 for the antenna category definition.

B.3 Setup Values for NFC Forum Reference Equipment

Table 7 lists the setup parameters for the NFC Forum Reference Equipment. For each of the parameters, when applicable, the minimum value, a nominal value and the maximum value are defined.

Table 7: Parameters for Setting Up Reference Equipment

Topic	Parameter	Coil	Setup Values to establish...			Units	RS,L Ω	fs,RES
			Min	Nominal	Max			MHz
Carrier Frequency	fs,c		13.55	13.56	13.57	MHz		13.56
Maximum Field Strength exposure	tMAX12			25		sec		
	tGT			30				
	tOFF			5				
	tMAX			300				
Power transfer: Poller→ Listener	Zs,ov		5	5	5	mm		
	Vs,ov Set up using Listener-1	Poller-0	4.70	5.22		V	820	13.56
		Poller-3	4.24	4.72				
		Poller-6	3.73	4.15				
	Vs,ov	Poller-0 with Listener-1			2.84	V	82	13.56
		Poller-3 with Listener-3			2.22			
		Poller-6 with Listener-6			2.05			
	Vs,ov,MAX10	Poller-0 with Listener-1			3.83	V	82	13.56
	Vs,ov,MAX12	Poller-0 with Listener-1			4.62	V	82	13.56
	Vs,ov,RESET using Listener-6	Poller 0	0		2.16	mV rms	82	13.56
		Poller 3	0		1,27			
		Poller 6	0		1,30			
	Vs,ov,RESET.T5T	Poller 0			0	mVrms	82	13.56
Poller 3				0				
Poller 6				0				
	Zs		5	5	5	mm		

Topic	Parameter	Coil	Setup Values to establish...			Units	RS,L Ω	f _{S,RES}
			Min	Nominal	Max			MHz
Poller RF Collision Avoidance	V_{s,thresh RF Collision Avoidance} using Listener-1 (PICC-1) Based on 0.1875 A/m on ID-1	Any Poller	0.573			V	820	13.56
Modulation Poller→ Listener (NFC-A)	Z_s		5	5	5	mm		
	t_{s,1,A} (106 kbps)		2.03	2.85	3.02	μs	820	13.56 & 16.00
	t_{s,2,A} (106 kbps)		0.44		t_{s,1}	μs		
	t_{s,3,A} (106 kbps)		Greater of 1.5 x t_{s,4} or minimum achievable value		1.25	μs		
	t_{s,4,A} (106 kbps)		Minimum achievable value		0.52	μs		
	V_{s,OU,A} (106 kbps)		0		$0 \leq t_3 \leq \frac{3}{f_c}$ $\Rightarrow \left(1 - \frac{t_3}{2 \cdot t_{3_max}}\right) \cdot 0.4$ $\frac{3}{f_c} \leq t_3 \leq \frac{6}{f_c}$ $\Rightarrow \frac{-y_1 + y_2}{3/f_c} \cdot t_3 + 2y_1 - y_2$ $\frac{6}{f_c} \leq t_3 \leq t_{3_max}$ $\Rightarrow \left(1 - \frac{t_3}{2 \cdot t_{3_max}}\right) \cdot 0.11$ with $y_1 = \left(1 - \frac{3/f_c}{2 \cdot t_{3_max}}\right) \cdot 0.4$ $y_2 = \left(1 - \frac{6/f_c}{2 \cdot t_{3_max}}\right) \cdot 0.11$	-	820	13.56 & 16.00
Modulation Poller→ Listener (NFC-B)	m_{s,i,B} (106 kbps)		7.5	11	19	%	820	13.56 & 16.00
	t_{s,f,B} (106 kbps)		Minimum achievable value		1.25	μs		
	t_{s,r,B} (106 kbps)		Maximum of minimum		Minimum of 1.25 and 0.66+ t_{s,f,B}	μs		

Topic	Parameter	Coil	Setup Values to establish...			Units	RS,L Ω	f _{S,RES}
			Min	Nominal	Max			MHz
			achievable value and t_{S,f,B}-0.66					
	V_{S,OU,B} (106 kbps)		0		$0 \leq t_{r,B} \leq \frac{3}{f_c}$ $\Rightarrow \left(1 - \frac{t_{r,B}}{2 \cdot t_{r,B_max}}\right) \cdot 0.4$ $\frac{3}{f_c} \leq t_{r,B} \leq \frac{6}{f_c}$ $\Rightarrow \frac{-y_1 + y_2}{3/f_c} \cdot t_{r,B} + 2y_1 - y_2$ $\frac{6}{f_c} \leq t_{r,B} \leq t_{r,B_max}$ $\Rightarrow \left(1 - \frac{t_{r,B}}{2 \cdot t_{r,B_max}}\right) \cdot 0.11$ <p style="text-align: center;">or</p> $0 \leq t_{f,B} \leq \frac{3}{f_c}$ $\Rightarrow \left(1 - \frac{t_{f,B}}{2 \cdot t_{f,B_max}}\right) \cdot 0.4$ $\frac{3}{f_c} \leq t_{f,B} \leq \frac{6}{f_c}$ $\Rightarrow \frac{-y_1 + y_2}{3/f_c} \cdot t_{f,B} + 2y_1 - y_2$ $\frac{6}{f_c} \leq t_{f,B} \leq t_{f,B_max}$ $\Rightarrow \left(1 - \frac{t_{f,B}}{2 \cdot t_{f,B_max}}\right) \cdot 0.11$ <p style="text-align: center;">with</p> $y_1 = \left(1 - \frac{3/f_c}{2 \cdot t_{r/f,B_max}}\right) \cdot 0.4$ $y_2 = \left(1 - \frac{6/f_c}{2 \cdot t_{r/f,B_max}}\right) \cdot 0.11$	-	820	13.56 & 16.00
Modulation Poller→ Listener (NFC-F)	m_{S,i,F}		7.5	11	19	%		
	t_{S,f,F} (212 kbps)		Minimum achievable value		1.25	μs		
	t_{S,f,F} (424 kbps)		Minimum achievable value		0.9	μs		
	t_{S,r,F} (212 kbps)		Maximum of minimum achievable value and t_{S,f,F}-0.66		Minimum of 1.25 and 0.66+ t_{S,f,F}	μs	820	13.56 & 16.00
	t_{S,r,F} (424 kbps)		Maximum of		Minimum of 0.9 and 0.44+ t_{S,f,F}	μs		

Topic	Parameter	Coil	Setup Values to establish...			Units	RS,L Ω	fs,RES
			Min	Nominal	Max			MHz
			minimum achievable value and ts,f,F-0.44					
	Vs,ou,F		0		$0 \leq t_{r,F} \leq \frac{3}{f_c}$ $\Rightarrow \left(1 - \frac{t_{r,F}}{2 \cdot t_{r,F_max}}\right) \cdot 0.40$ $\frac{3}{f_c} \leq t_{r,F} \leq \frac{6}{f_c}$ $\Rightarrow \frac{-y_1 + y_2}{3/f_c} \cdot t_{r,F} + 2y_1 - y_2$ $\frac{6}{f_c} \leq t_{r,F} \leq t_{r,F_max}$ $\Rightarrow \left(1 - \frac{t_{r,F}}{2 \cdot t_{r,F_max}}\right) \cdot 0.11$ <p style="text-align: center;">or</p> $0 \leq t_{f,F} \leq \frac{3}{f_c}$ $\Rightarrow \left(1 - \frac{t_{f,F}}{2 \cdot t_{f,F_max}}\right) \cdot 0.4$ $\frac{3}{f_c} \leq t_{f,F} \leq \frac{6}{f_c}$ $\Rightarrow \frac{-y_1 + y_2}{3/f_c} \cdot t_{f,F} + 2y_1 - y_2$ $\frac{6}{f_c} \leq t_{f,F} \leq t_{f,F_max}$ $\Rightarrow \left(1 - \frac{t_{f,F}}{2 \cdot t_{f,F_max}}\right) \cdot 0.11$ <p style="text-align: center;">with</p> $y_1 = \left(1 - \frac{3/f_c}{2 \cdot t_{r/f,F_max}}\right) \cdot 0.4$ $y_2 = \left(1 - \frac{6/f_c}{2 \cdot t_{r/f,F_max}}\right) \cdot 0.11$	-	820	13.56 & 16.00
Modulation Poller→ Listener (NFC-V)	Zs		5	5	5	mm		
	ts,1,v (26 kbps)		6	7,74	9.44	μs		
	ts,2,v (26 kbps)		2.1		ts,1,v	μs		
	ts,3,v (26 kbps)		Greater of 1.5 x ts,4,v or minimum achievable value		4.5	μs	820	13.56 & 16.00

Topic	Parameter	Coil	Setup Values to establish...			Units	R _{S,L} Ω	f _{S,RES}
			Min	Nominal	Max			MHz
	t_{s,4,v} (26 kbps)		Minimum achievable value		0.8	μs		
	V_{s,ou,v} (26 kbps)		0		$0 \leq t_3 \leq \frac{3}{f_c}$ $\Rightarrow \left(1 - \frac{t_3}{2 \cdot t_{3_max}}\right) \cdot 0.4$ $\frac{3}{f_c} \leq t_3 \leq \frac{6}{f_c}$ $\Rightarrow \frac{-y_1 + y_2}{3/f_c} \cdot t_3 + 2y_1 -$ $\frac{6}{f_c} \leq t_3 \leq t_{3_max}$ $\Rightarrow \left(1 - \frac{t_3}{2 \cdot t_{3_max}}\right) \cdot 0.11$ with $y_1 = \left(1 - \frac{3/f_c}{2 \cdot t_{3_max}}\right) \cdot 0.$ $y_2 = \left(1 - \frac{6/f_c}{2 \cdot t_{3_max}}\right) \cdot 0.$	-	820	13.56 & 16.00
Load Modulation (NFC-A, NFC-B, NFC-F, NFC-V)	Z_{S,LM}		5	5	5	mm		
	V_{S,LMA} with Poller-0	Listener-1	5.6	7		mVp	330	16.00
		Listener-3	7.5	9				
	Listener-6	6.9	9					
Load Modulation (NFC-A, NFC-B, NFC-F, NFC-V)	V_{S,LMA}	Poller-0 with Listener-1			54.4	mVp	820	13.56
		Poller-3 with Listener-3			33.0			
		Poller-6 with Listener-6			38.0			

B.4 NFC Forum Listeners Antenna Category Definitions

To ensure interoperability of an NFC Forum Listener with systems that are based on ISO/IEC 14443, the NFC Forum defines different load modulation amplitude limit values, depending on the antenna size of the NFC Forum Listener. Only the active antenna size used for load modulation is affected by this definition. This section defines the rules for selecting the correct antenna size category. If none of the category selection criteria apply for the Listener antenna size, the default category SHALL be used. The category selection is based on the outer and inner area enclosed by the antenna:

- The outer area is defined as the area enclosed by the outermost conductor of the antenna.
- The inner area is defined as the area enclosed by the innermost conductor of the antenna (enclosed by the antenna).

The 3 categories are defined below and are summarized in Table 8:

- **Category A (CAT A):** The Antenna encloses at least an inner area of 2180 mm². If not designed as a circle, an aspect ratio of 19:10 for the inner area SHALL not be exceeded.
- **Category B (CAT B):** The Antenna encloses at least an inner area of 840 mm² but does not exceed an outer area of 2180 mm², except for connections. If not designed as a circle, an aspect ratio of 3:2 for the inner area SHALL not be exceeded.
- **Category C (CAT C), default category:** The antenna area does not exceed an outer area of 840 mm², except for connections, or does not fit into **Category A** or **Category B**.

Table 8: NFC Forum Listener antenna size definition

Antenna size	Category A	Category B	Category C, default category
Outer area (maximum)	-	2180 mm ²	840 mm ²
Inner area (minimum)	2180 mm ²	840 mm ²	-

Examples for Antenna Size to Category Assignment

This section provides examples for antenna size categorization.

Example for Antenna Category A:

This example shows the Category A antenna of the NFC Forum Device. The inner area is implemented as a rectangle, respecting the minimum area and aspect ratio for Category A. Since there are no limitations for the outer area, the antenna can be aligned with non-antenna areas in the NFC Forum Device.

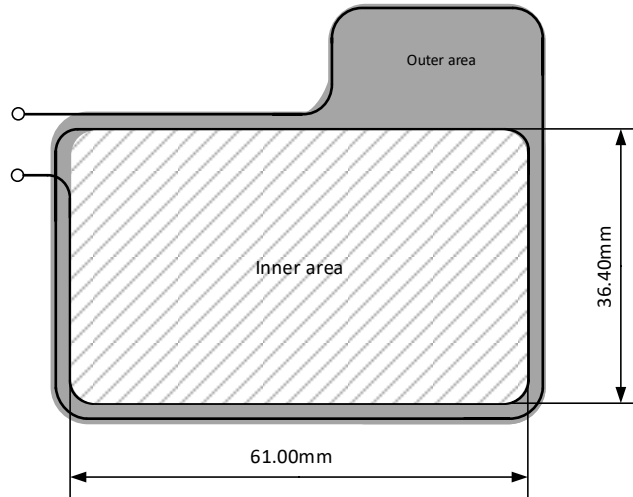

Figure 16: Example of an antenna for Category A

Table 9: Category A example dimensions and limits

Units	Example - antenna CAT A				CAT A limit	
	a (mm)	b (mm)	aspect ratio	area (mm ²)	aspect ratio	area (mm ²)
Inner	61.00	36.40	1.67	2224.04	max 19/10	min 2180
Outer	-	-	-		-	-

Example for Antenna Category B:

In this example the NFC Forum Device uses a complex antenna arrangement consisting of two individual antennas. In Poll Mode the NFC Forum Device uses both antennas, the solid and the dashed antennas shown in Figure 17. In Listen Mode the NFC Forum Device uses the antenna indicated by solid lines in Figure 17.

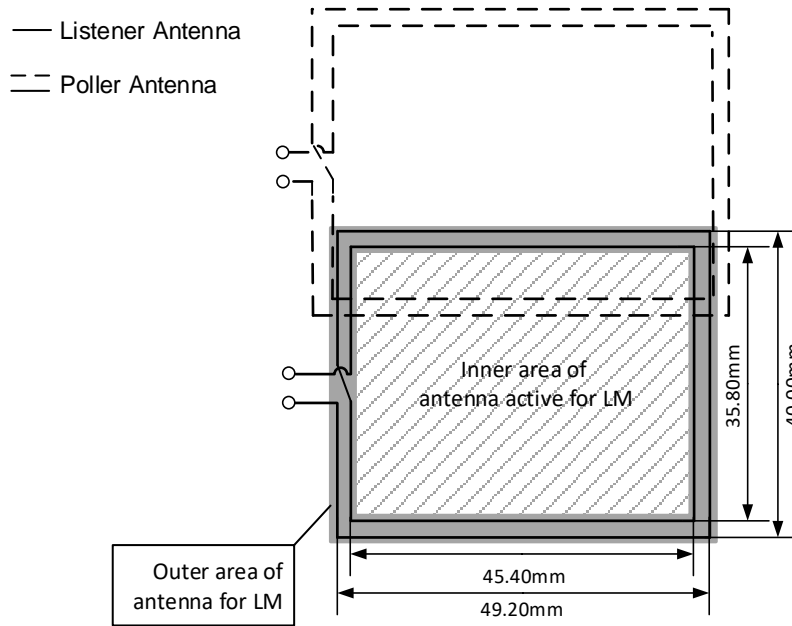

Figure 17: Example of an antenna for Category B

Table 10: Category B example dimensions and limits

	Example - antenna CAT B				CAT B limit	
Units	a (mm)	b (mm)	aspect ratio	area (mm ²)	aspect ratio	area (mm ²)
Inner	45.40	35.80	1.27	1625.32	max 3/2	min 840
Outer	49.20	40.00	1.23	1968	-	max 2180

Example for Antenna Category C:

In this example the NFC Forum Device uses a Category C Antenna.

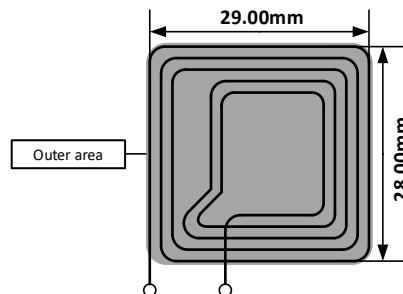

Figure 18: Example of an antenna for Category C

Table 11: Category C example dimensions and limits

	Example - antenna CAT C, default				CAT C limit	
Units	a (mm)	b (mm)	aspect ratio	area (mm ²)	aspect ratio	area (mm ²)
Inner	-	-	-	-	-	-
Outer	29.00	28.00	29/28	812.00	-	max 840

Example for Antenna Category C, default Category assignment:

In this example the antenna area and aspect ratio do not fit into any of the defined antenna Categories and therefore this antenna is assigned to the default Category, which is Category C.

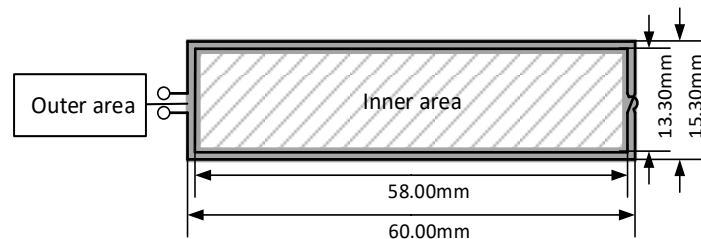
Figure 19: Example of an antenna for default Category which is Category C
Table 12: Default Category C example dimensions and limits

	Example - antenna CAT C, default				Default CAT C limit	
Units	a (mm)	b (mm)	aspect ratio	area (mm ²)	aspect ratio	area (mm ²)
Inner	58.00	13.30	4.36	771.40	-	-
Outer	60.00	15.30	3.92	918.00	-	max 840

B.5 Calibration Procedure for Reference Pollers

The preferred method for calibration or verification is by using a Vector Network Analyzer (VNA).

The Reference Poller SHALL be positioned in free air. A short length of semi-rigid RG-402 cable is ideal for this purpose.

The analyzer is used to perform a reflection measurement (S11) after the VNA is calibrated using Open, Short, Load (OSL) 1 port calibration. The calibration plane for this corresponds to the mating surface of the Subminiature version A (SMA) plug on the cable from the VNA that will be connected to the SMA socket of the Reference Equipment. See Figure 20.

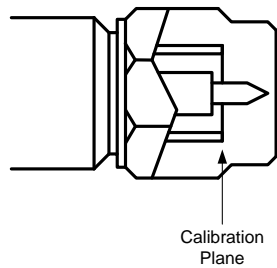

Figure 20: Calibration Plane of SMA Plug and Socket

The VNA is connected to J1, the socket that accepts the carrier from the power amplifier. The socket that connects to the Sense Resistor (J2) SHALL be terminated with a 50 Ω load during calibration and use.

The VNA SHALL be set to a drive level of 0 dBm and the scan and steps adjusted to ensure adequate resolution and accuracy for the measurement (for example, scanning from 13 to 14 MHz with 1000 points in the scan). Set up the VNA in S11 measurement mode, and display the return loss.

Use a non-metallic tuning tool appropriate for the trimmer capacitors VC1 and VC2, and tune it in order to achieve maximum return loss at 13.56 MHz and 50 Ω matching. A Reference Poller is correctly tuned when the return loss is greater than 45 dB at 13.56 MHz. Note that VC2 affects matching and tuning, whereas VC1 primarily affects tuning.

Figure 21 shows an example of a typical VNA display while tuning a Reference Poller.

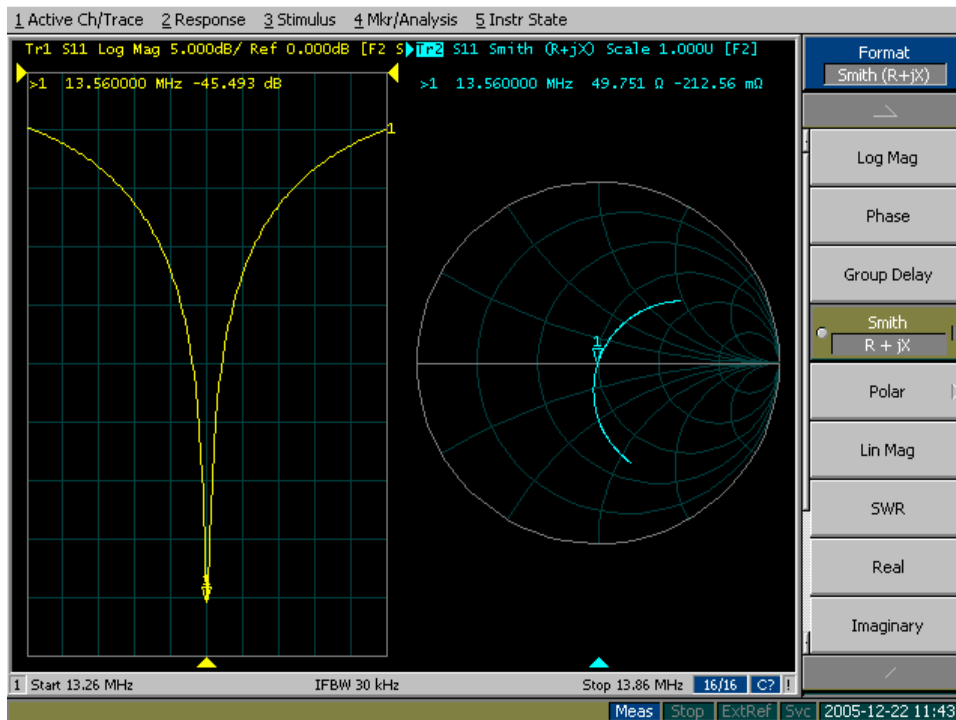

Figure 21: Example of VNA Display while Tuning a Reference Poller

B.6 Calibration Procedure for Reference Listeners

The preferred method for calibration or verification is by using a Vector Network Analyzer (VNA).

The Reference Listener SHALL be positioned in free air. A short length of semi-rigid RG-402 cable is ideal for this purpose.

The 820 Ω fixed load SHALL be selected.

The analyzer is used to perform a reflection measurement (S11) after calibrating the VNA using Open, Short, Load (OSL) calibration. The calibration plane for this corresponds to the mating surface of the SMA plug on the cable from the VNA that will be connected to the SMA socket of the Reference Equipment. See Figure 20.

The VNA is connected to J5, the SMA socket in parallel with the antenna coil. While the Reference Listener is being calibrated, there SHALL be no connection made to any of the other connectors of the device.

The VNA SHALL be set to a drive level of +10 dBm and the scan and steps adjusted to ensure adequate resolution and accuracy for the measurement (for example, scanning from 10 to 20 MHz with 1000 points in the scan).

Set up the VNA in S11 measurement mode and display impedance as modulus and phase. At the resonance frequency of the Reference Listener antenna, note the peak of the impedance and zero degree phase shift.

Use a non-metallic tuning tool appropriate for the trimmer capacitor VC1, and tune it in order to achieve close to zero degree phase shift (which is expected to correspond approximately to the peak $|Z|$) at the respective resonance frequency (e.g. 13,56MHz or 16MHz depending on the definition in B2 and B3). A Reference Listener is correctly tuned when its resonance is within 50 kHz of the intended frequency.

Figure 22 shows an example of a typical VNA display while tuning a Reference Listener.

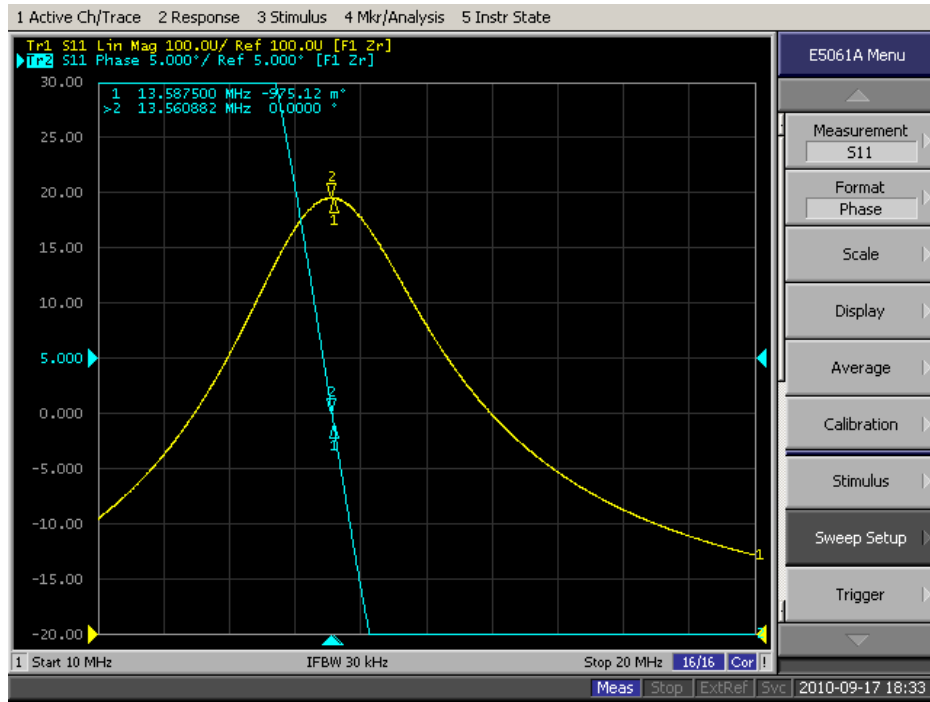

Figure 22: Example of VNA Display while Tuning a 13,56MHz Reference Listener

B.7 Nominal or Maximal Settings for NFC Forum Reference Equipment

Table 13: Setup for Nominal or Maximal Field Strength

Step	Action
1	Place the Reference Listener in position ($z = Z_{s,ov}$, $r=0$, $\varphi=0$, $\theta=0$) of the Operating Volume of the Reference Poller. Apply no modulation transmit signal to J2 of the Reference Listener. Configure the Reference Listener with resistive load $R_{s,L}$ for $V_{s,ov}$ (Nominal or Maximal value). Refer to Appendix B.3 for the values of $Z_{s,ov}$ and $R_{s,L}$.
2	Connect input J1 of the Reference Poller with a signal generator V generating a carrier signal with frequency $f_{s,c}$ (nominal value). Regulate the signal generator V in such a way that it generates an average voltage $V_{s,ov}$ (nominal or maximal value) at J1 of the Reference Listener. Refer to Appendix B.3 for the values of $V_{s,ov}$ and $f_{s,c}$.
3	Remove the Reference Listener from the Operating Volume of the Reference Poller.

Table 14: Setup for Nominal Modulation

Step	Action
1	Place the Reference Listener ($z = Z_{s,ov}$, $r=0$, $\varphi=0$, $\theta=0$) of the Operating Volume of the Reference Poller. Apply no modulation transmit signal to J2 of the Reference Listener. Configure the Reference Listener with resistive load $R_{s,L}$ for “Modulation Poller→Listener” for NFC-A, NFC-B, NFC-F or NFC-V as appropriate. Refer to Appendix B.3 for the values of $Z_{s,ov}$ and $R_{s,L}$.
2	Modulate the carrier to obtain the following modulation characteristics: For NFC-A: <ul style="list-style-type: none"> • Nominal value of ts_1 • ts_2, ts_3, ts_4, and $V_{s,ou,A}$ are within Min-Max range For NFC-B: <ul style="list-style-type: none"> • Nominal value of $m_{s,i,B}$ • $ts_{f,B}$, $ts_{r,B}$, and $V_{s,ou,B}$ are within Min-Max range For NFC-F: <ul style="list-style-type: none"> • Nominal value of $m_{s,i,F}$ • $ts_{f,F}$, $ts_{r,F}$, and $V_{s,ou,F}$ are within Min-Max range The modulation characteristics are measured at the output of the 8-Shaped Coil, as described in Appendix C. Refer to Appendix B.3 for the nominal values of ts_1 , $m_{s,i,B}$, and $m_{s,i,F}$ and for the ranges for ts_2 , ts_3 , ts_4 , $V_{s,ou,A}$, $ts_{f,B}$, $ts_{r,B}$, $V_{s,ou,B}$, $ts_{f,F}$, $ts_{r,F}$, and $V_{s,ou,F}$. For NFC-V <ul style="list-style-type: none"> • Nominal value of $ts_{1,v}$ • $ts_{2,v}$, $ts_{3,v}$, $ts_{4,v}$, $ts_{5,v}$, and $V_{s,ou,v}$ are within Min-Max range
3	Remove the Reference Listener from the Operating Volume of the Reference Poller.

B.8 Orientation and Alignment of NFC Forum Reference Equipment

Each Reference Poller has an alignment legend that consists of an arrow and a cross mark that are centered on the geometrical center of the antenna. The arrow points away from the components.

Each NFC Forum – Reference Listener Device has an alignment legend that consists of an arrow and a cross mark that are centered on the geometrical center of the antenna. The arrow points toward the components.

Both devices are intended to be presented to the Poller or Listener to be characterized in an orientation in which the components are uppermost. In this orientation the thickness of the PCB and stack-up of the layers are used to generate a consistent $z=0$ separation. Therefore, it is important that the construction details given in Appendix C.10 be adopted.

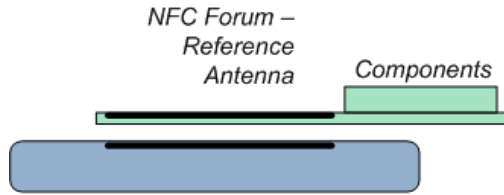

Figure 23: Orientation of NFC Forum Reference Equipment Used To Characterize a Polling or Listener

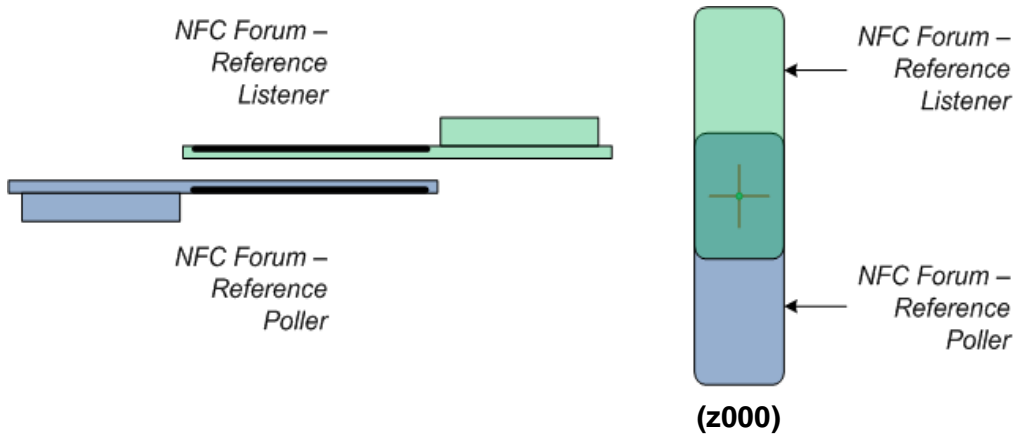

Figure 24: Relative Orientation of NFC Forum Reference Equipment During Setup

and 8-Shaped Coil

C. Design Information for NFC Forum Reference Equipment and 8-Shaped Coil

This appendix provides design information essential for defining the Reference Poller and the Reference Listeners.

Fixed components used in these circuits SHALL have tolerance $\leq 2\%$. High stability capacitors, e.g., NPO/COG with 50 V DC rating, SHOULD be used.

C.1 Reference Poller-0

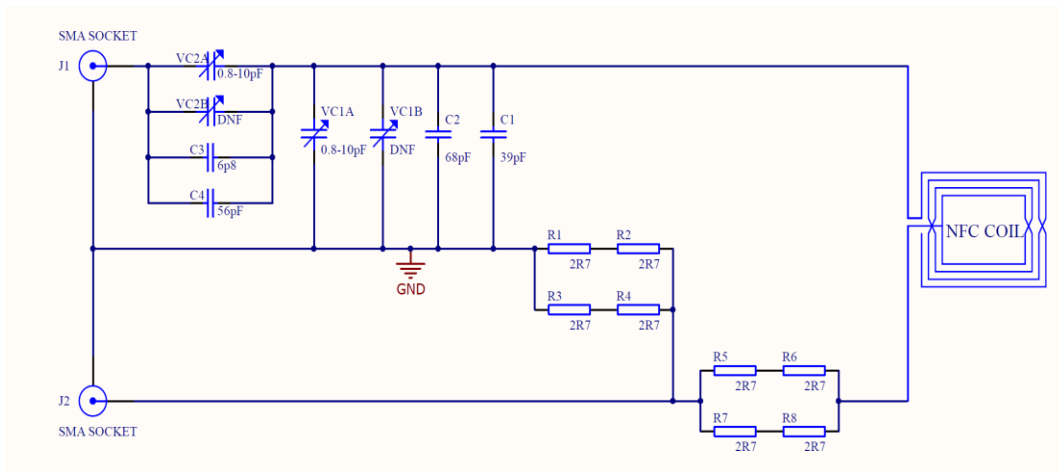

Figure 25: Circuit for Reference Poller-0

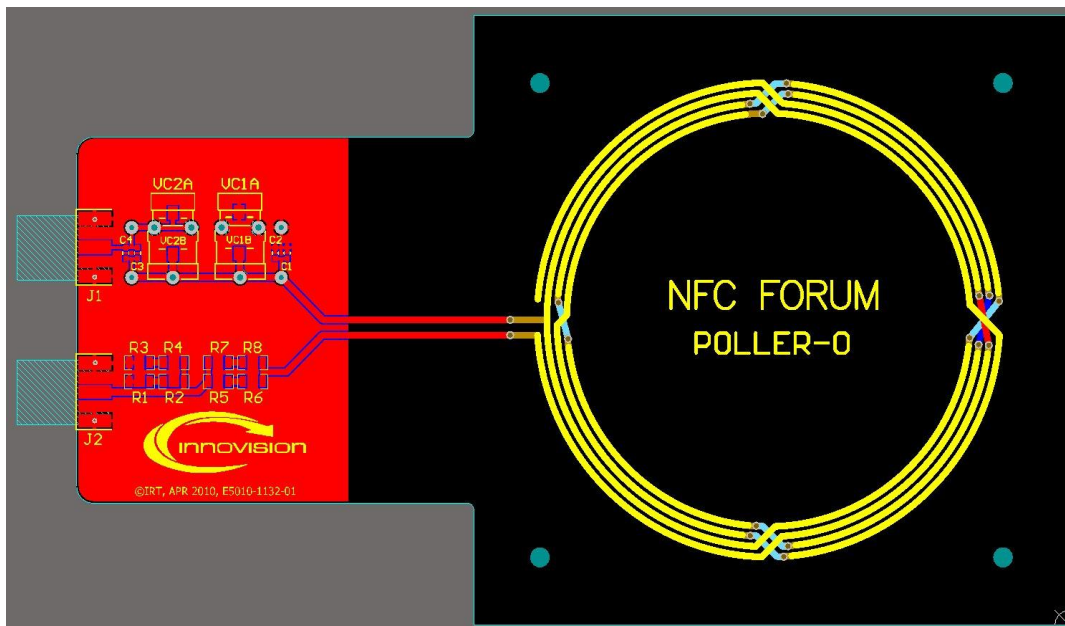

Figure 26: PCB Layout for Reference Poller-0

and 8-Shaped Coil

C.2 Reference Poller-3

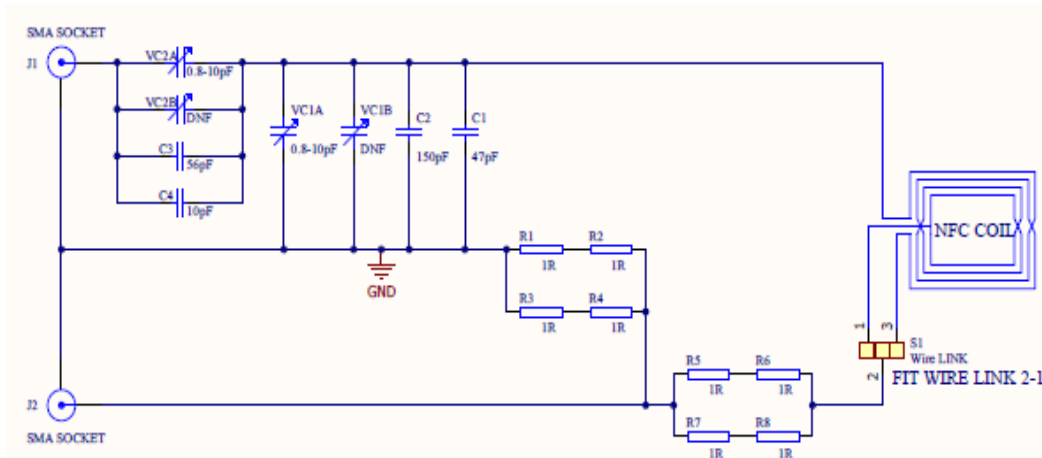

Figure 27: Circuit for Reference Poller-3

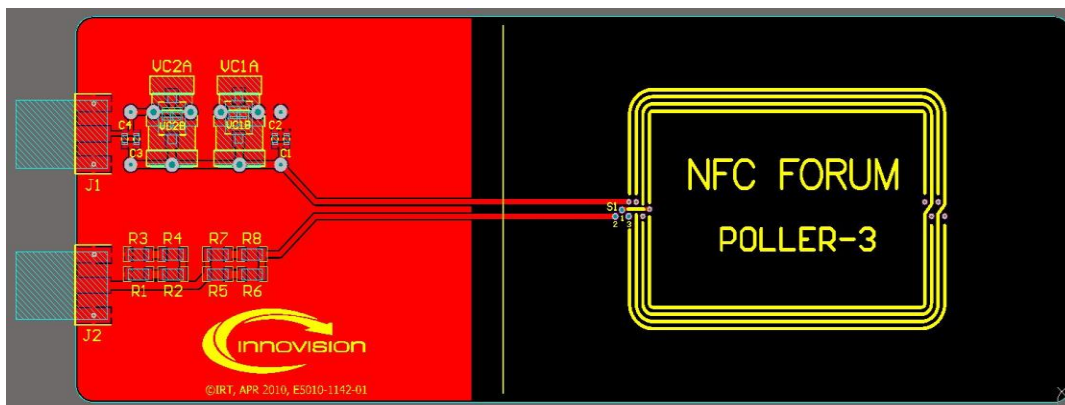

Figure 28: PCB Layout for Reference Poller-3

and 8-Shaped Coil

C.3 Reference Poller-6

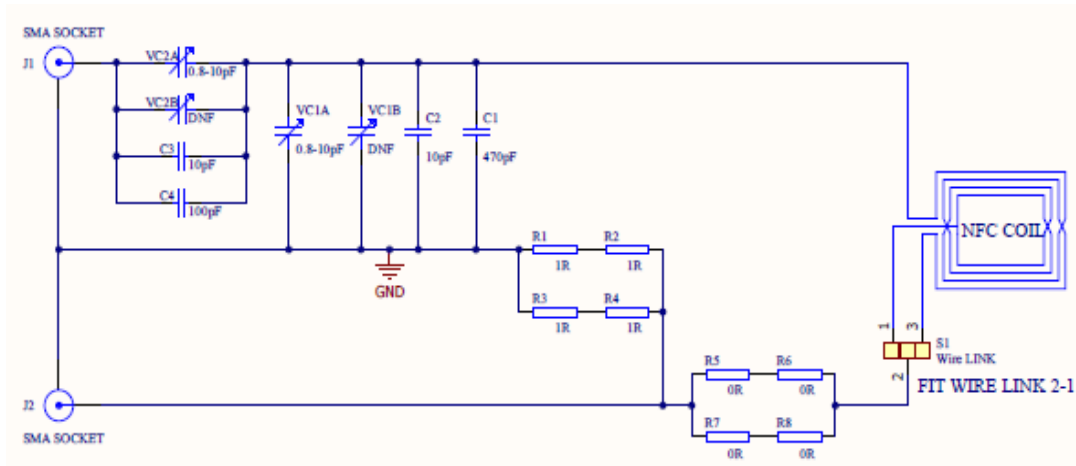

Figure 29: Circuit for Reference Poller-6

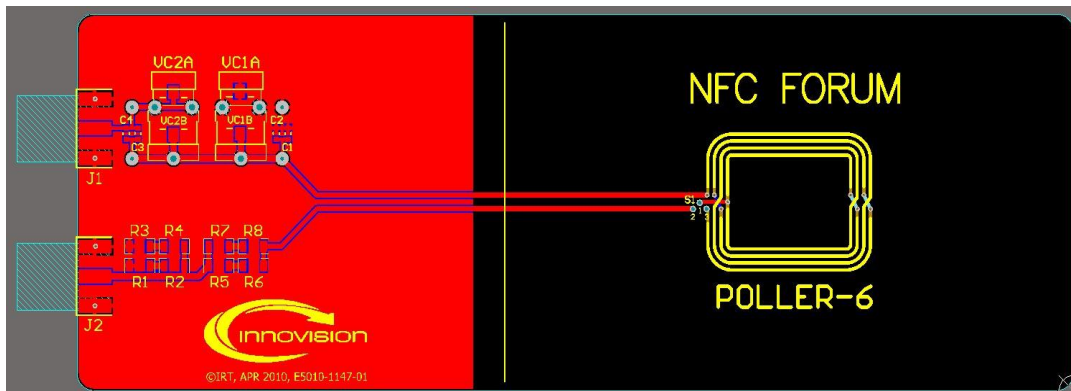

Figure 30: PCB Layout for Reference Poller-6

and 8-Shaped Coil

C.4 Reference Poller - Bill Of Material

Description	Designator	Quantity	Value/ Manufacturer	Dielectric Rating	Tolerance	Package
Capacitor	C1	1	39 pF (Poller-0) 47 pF (Poller-3) 470 pF (Poller-6)	NP0/COG- 50 VDC	<2%	CAP_0603
Capacitor	C2	1	68 pF (Poller-0) 150 pF (Poller-3) 10 pF (Poller-6)	NP0/COG- 50 VDC	<2%	CAP_0603
Capacitor	C3	1	6.8 pF (Poller-0) 56 pF (Poller-3) 10 pF (Poller-6)	NP0/COG- 50 VDC	<2%	CAP_0603
Capacitor	C4	1	56 pF (Poller-0) 10 pF (Poller-3) 100 pF (Poller-6)	NP0/COG- 50 VDC	<2%	CAP_0603
Capacitor - Variable	VC1A	1	0.8 – 10 pF	AIR CAP- 250 VDC		Johanson PTH
Capacitor - Variable	VC2A	1	0.8 – 10 pF	AIR CAP- 250 VDC		Johanson PTH
Capacitor - Variable	VC1B	1	Do not Populate			TZB4 Type B SMT
Capacitor - Variable	VC2B	1	Do not Populate			TZB4 Type B SMT
Resistor	R1	1	2.7 Ω (Poller-0) 1 Ω (Poller-3) 1 Ω (Poller-6)	THICK FILM- 125 mW	1%	RES_1206
Resistor	R2	1	2.7 Ω (Poller-0) 1 Ω (Poller-3) 1 Ω (Poller-6)	THICK FILM- 125 mW	1%	RES_1206
Resistor	R3	1	2.7 Ω (Poller-0) 1 Ω (Poller-3) 1 Ω (Poller-6)	THICK FILM- 125 mW	1%	RES_1206
Resistor	R4	1	2.7 Ω (Poller-0) 1 Ω (Poller-3) 1 Ω (Poller-6)	THICK FILM- 125 mW	1%	RES_1206
Resistor	R5	1	2.7 Ω (Poller-0) 1 Ω (Poller-3) 0 Ω (Poller-6)	THICK FILM- 125 mW	1%	RES_1206
Resistor	R6	1	2.7 Ω (Poller-0) 1 Ω (Poller-3) 0 Ω (Poller-6)	THICK FILM- 125 mW	1%	RES_1206
Resistor	R7	1	2.7 Ω (Poller-0) 1 Ω (Poller-3) 0 Ω (Poller-6)	THICK FILM- 125 mW	1%	RES_1206
Resistor	R8	1	2.7 Ω (Poller-0) 1 Ω (Poller-3) 0 Ω (Poller-6)	THICK FILM- 125 mW	1%	RES_1206
Connector - SMA	J1, J2	2	SMA_SOCKET _END_LAUNC H			

NOTE The capacitor and resistor values are to be selected according to the Reference Poller number (0, 3 or 6).

C.5 Reference Listener-1

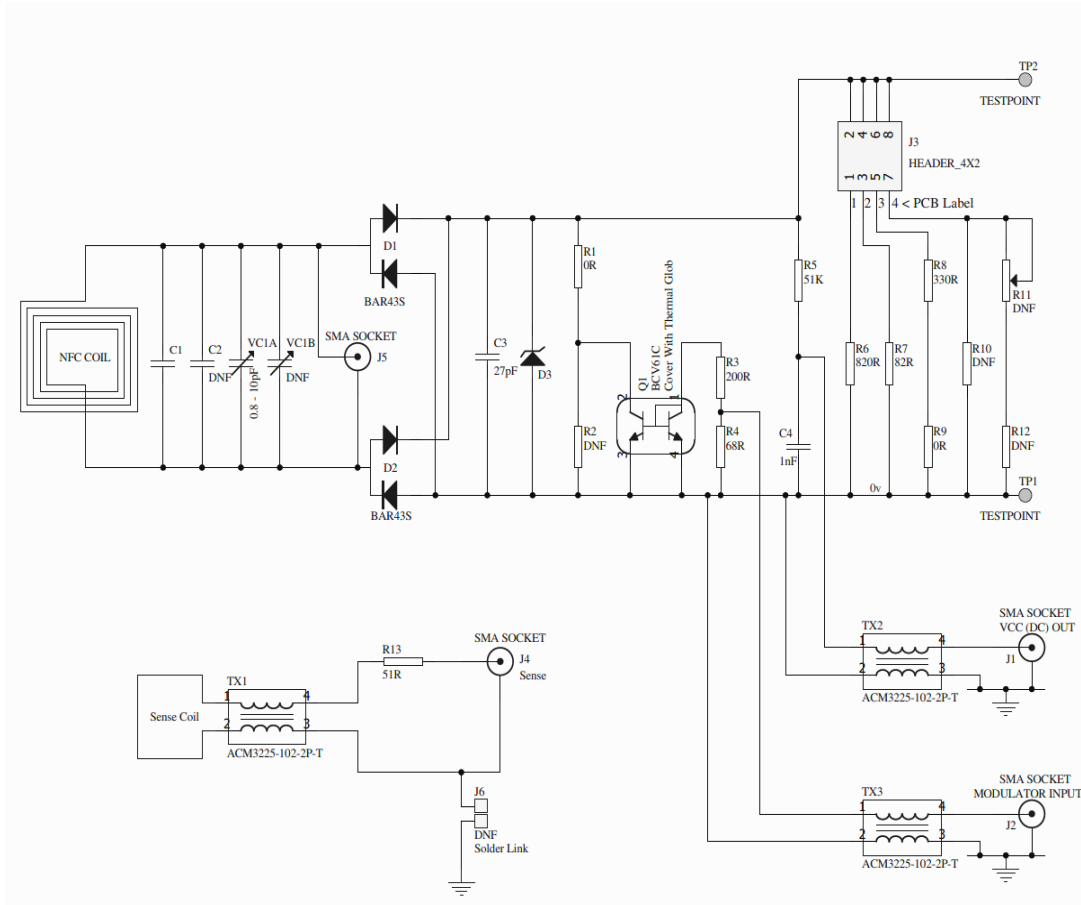

Figure 31: Circuit for Reference Listener-1

NOTE D3 is BZV55-C27.

NOTE During assembly be sure to crop the legs of J5 and VC1A flush with the underside of the PCB prior to soldering, so that z=0 can be reliably achieved in operation.

and 8-Shaped Coil

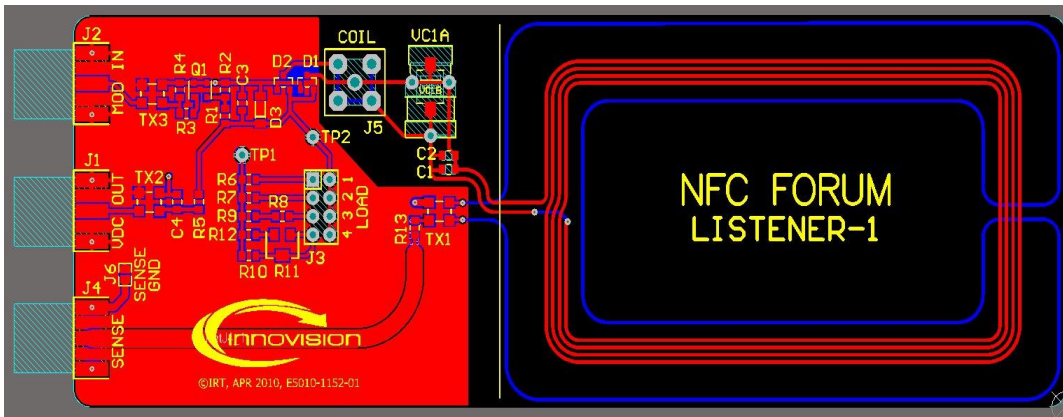

Figure 32: PCB Layout for Reference Listener-1

C.6 Reference Listener-3

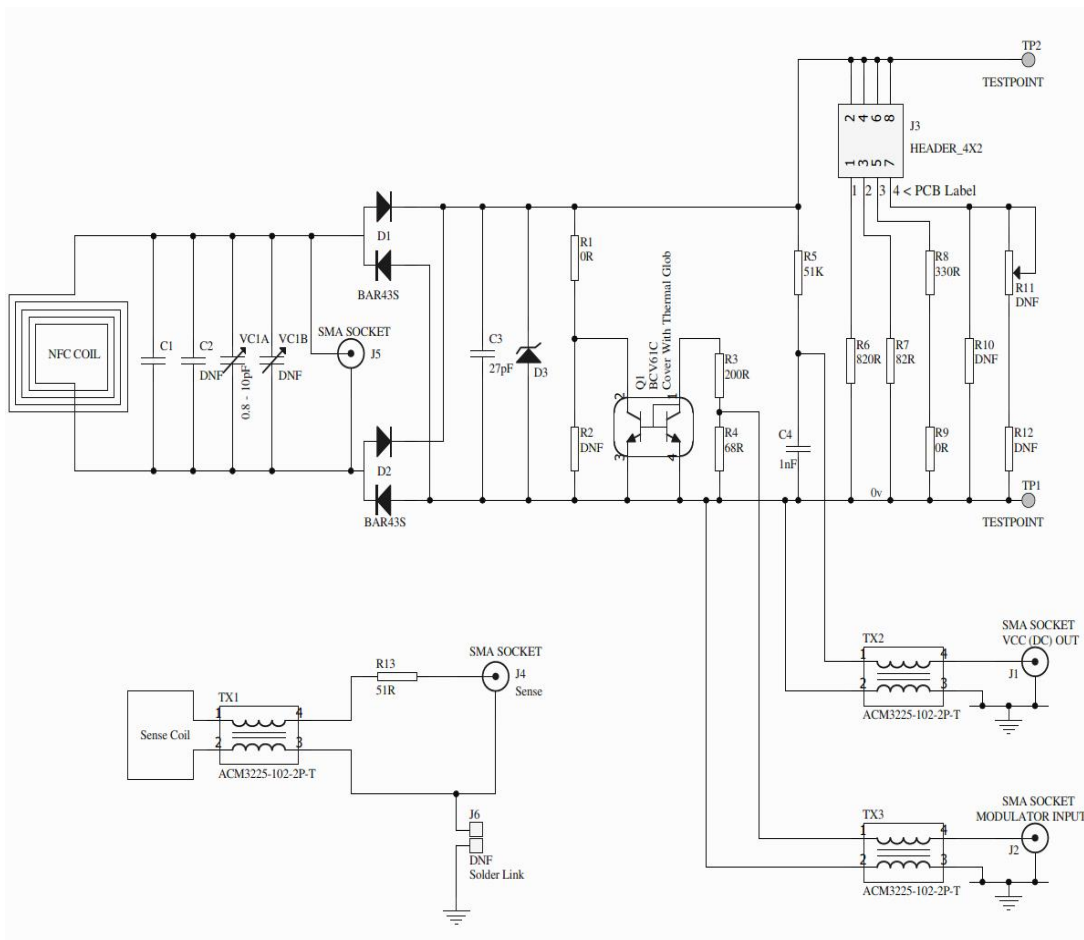

Figure 33: Circuit for Reference Listener-3

NOTE D3 is BZV55-C27

and 8-Shaped Coil

NOTE During assembly be sure to crop the legs of J5 and VC1A flush with the underside of the PCB prior to soldering, so that z=0 can be reliably achieved in operation.

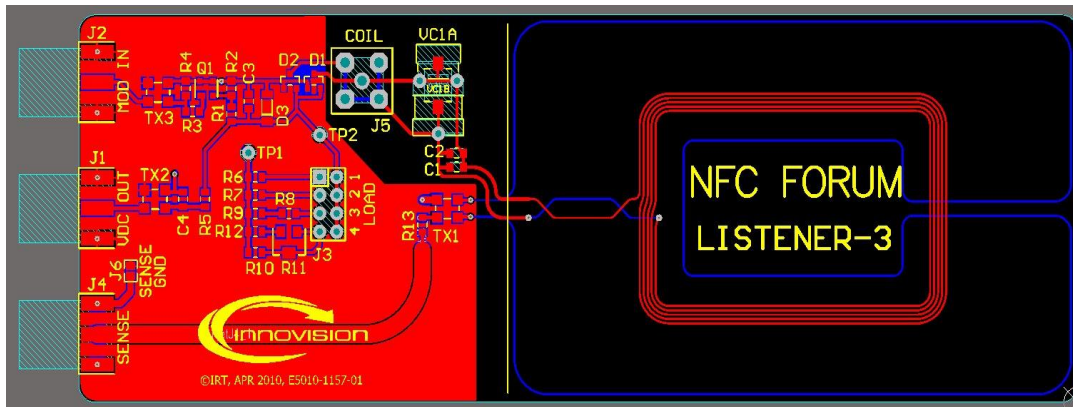

Figure 34: PCB Layout for Reference Listener-3

C.7 Reference Listener-6

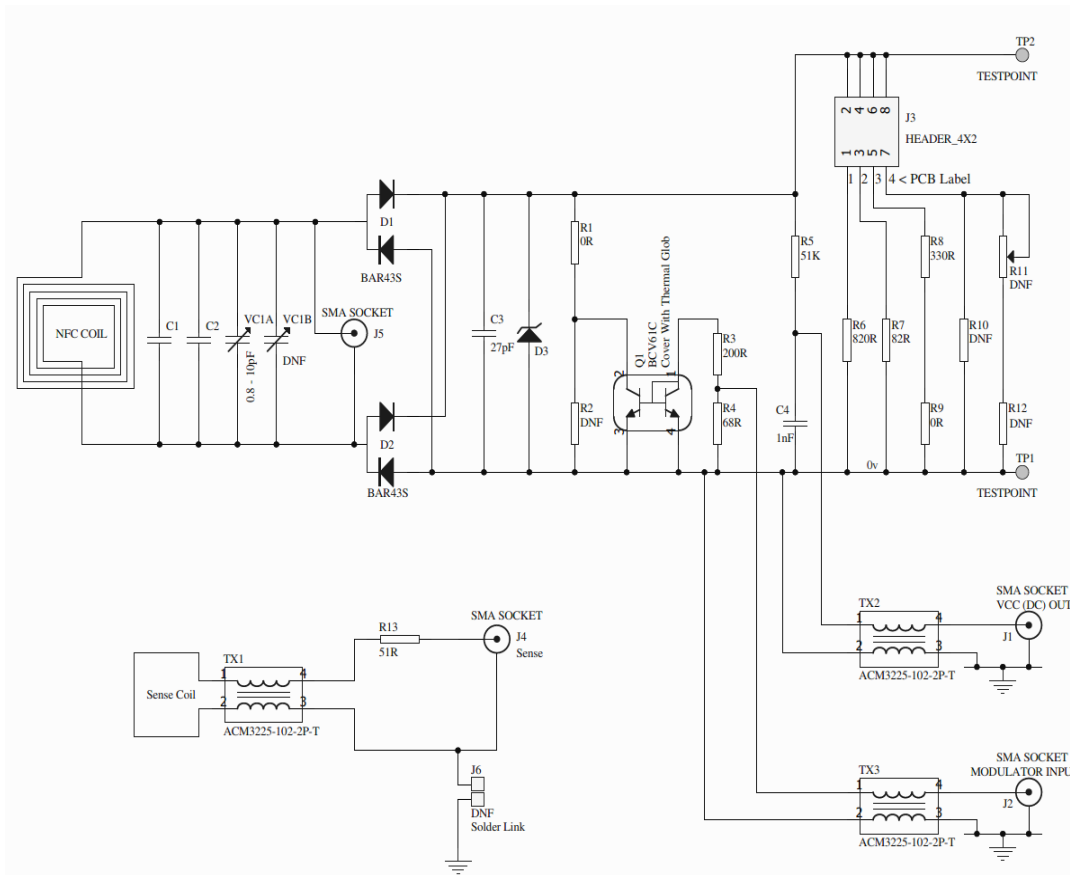

Figure 35: Circuit for Reference Listener-6

and 8-Shaped Coil

NOTE D3 is BZV55-C27

NOTE During assembly be sure to crop the legs of J5 and VC1A flush with the underside of the PCB prior to soldering, so that z=0 can be reliably achieved in operation.

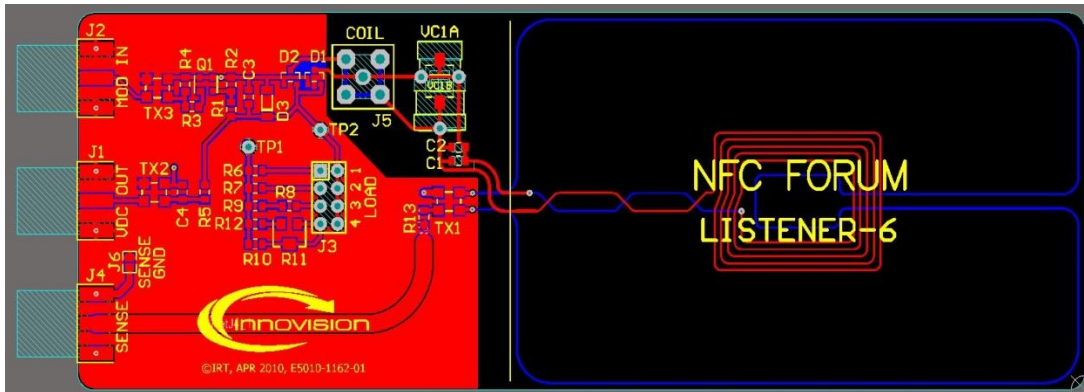

Figure 36: PCB Layout for Reference Listener-6

and 8-Shaped Coil

C.8 Reference Listener - Bill Of Material

Description	Designator	Quantity	Value/Manufacturer		Dielectric Rating	Tolerance	Package
Choke	TX1, TX2, TX3	3	TDK ACP3225-102-2P-T				IND_ACM3225
Capacitor	C1	1	f _{RES} : 13.56 MHz	* 33 pF (Listeners 1&3) * 100 pF (Listener 6)	NP0/COG-50 VDC	<2%	CAP_0805
			f _{RES} : 16 MHz	* 15 pF (Listeners 1&3) * 82 pF (Listener 6)			
Capacitor	C2	1	f _{RES} : 13.56 MHz	* Do not Populate (Listeners 1&3) * 39 pF (Listener 6)	NP0/COG-50 VDC	<2%	CAP_0805
			f _{RES} : 16 MHz	* Do not Populate (Listeners 1&3) * 8.2 pF (Listener 6)			
Capacitor	C3	1	27 pF		NP0/COG-50 VDC	<2%	CAP_0805
Capacitor	C4	1	1 nF		NP0/COG-50 VDC	<2%	CAP_0805
Capacitor - Variable	VC1A	1	0.8 - 10 pF		AIR CAP- 250 VDC		Johanson 5201
Capacitor - Variable	VC1B	1	Do not Populate				CAP_TRIM_SMT_TZB4
Diode Pair	D1, D2	2	BAR43S (End of Life) BAT54SLT1G (Alternative)				SOT-23
Diode - Zener	D3	1	BZV55C27				MINI-MELF
Resistor	R1, R9	2	0 Ω		THICK FILM-125 mW	1%	RES_0805
Resistor	R3	1	200 Ω		THICK FILM-125 mW	1%	RES_0805
Resistor	R4	1	68 Ω		THICK FILM-125 mW	1%	RES_0805
Resistor	R6	1	820 Ω		THICK FILM-500 mW	1%	RES_0805
Resistor	R7	1	82 Ω		THICK FILM-500 mW	1%	RES_0805
Resistor	R5	1	51 kΩ		THICK FILM-125 mW	1%	RES_0805
Resistor	R8	1	330 Ω		THICK FILM-500 mW	1%	RES_0805
Resistor	R13	1	51 Ω		THICK FILM-125 mW	1%	RES_0805
Resistor	R2, R10, R12	3	Do not Populate				RES_0805
Resistor - Potentiometer	R11	1	Do not Populate				VR_SMT_3214W
Current Mirror	Q1	1	BCV61C				SOT-143
Test Point	TP1, TP2	2	TESTPOINT				
Connector	J3	1	HEADER_4X2				
Connector - SMA	J1, J2, J4	3	SMA_SOCKET_END_LAUNCH				
Connector - SMA	J5	1	SMA_SOCKET				
Single Blob Link	J6	1	Do not Populate				

and 8-Shaped Coil

NOTE The C1 and C2 values are to be selected according to the Reference Listener.

C.9 Mechanical Dimensions of Pollers and Listeners

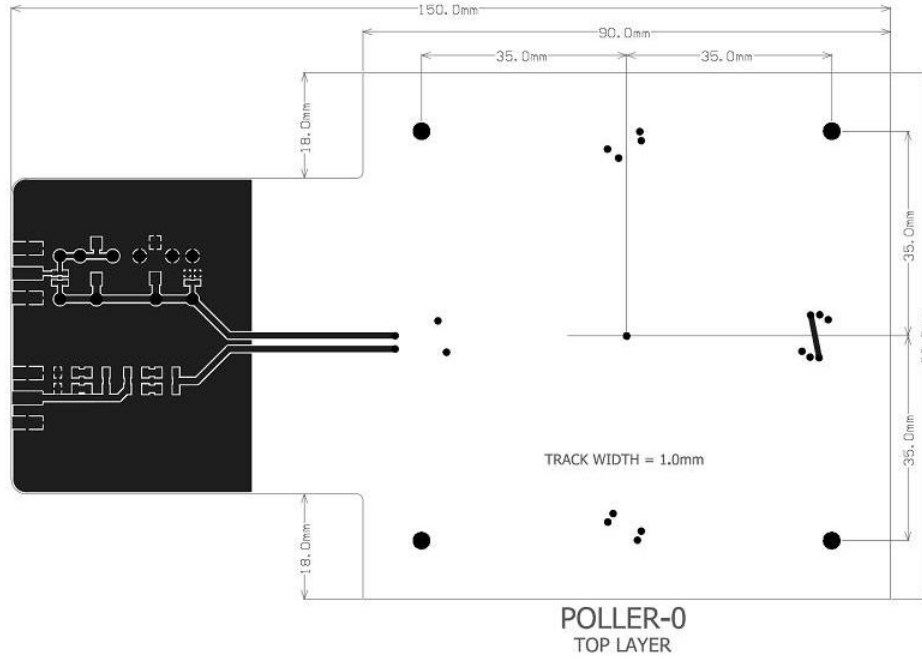

Figure 37: Reference Poller-0 Top Layer

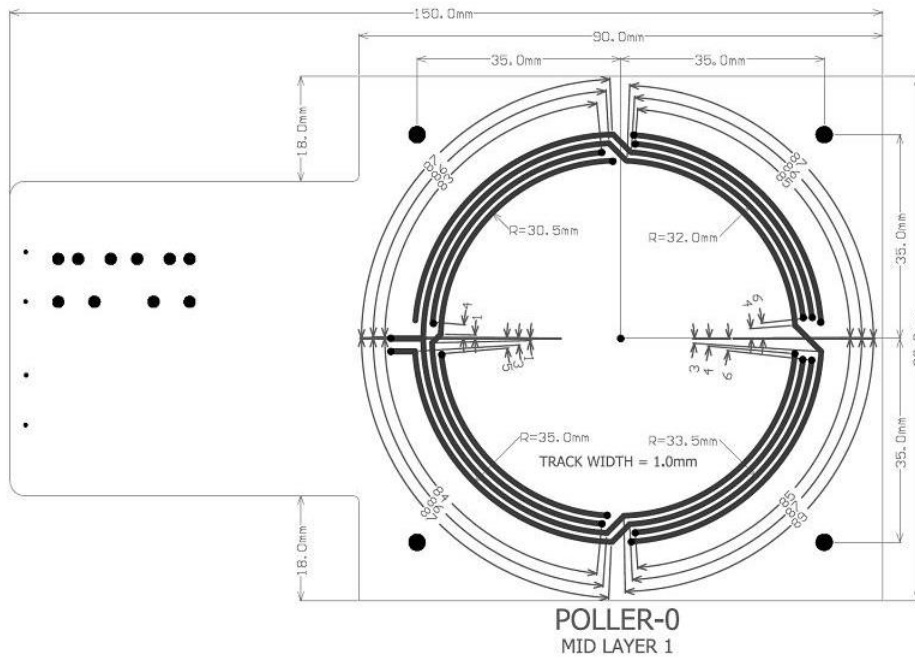

Figure 38: Reference Poller-0 Mid Layer 1

and 8-Shaped Coil

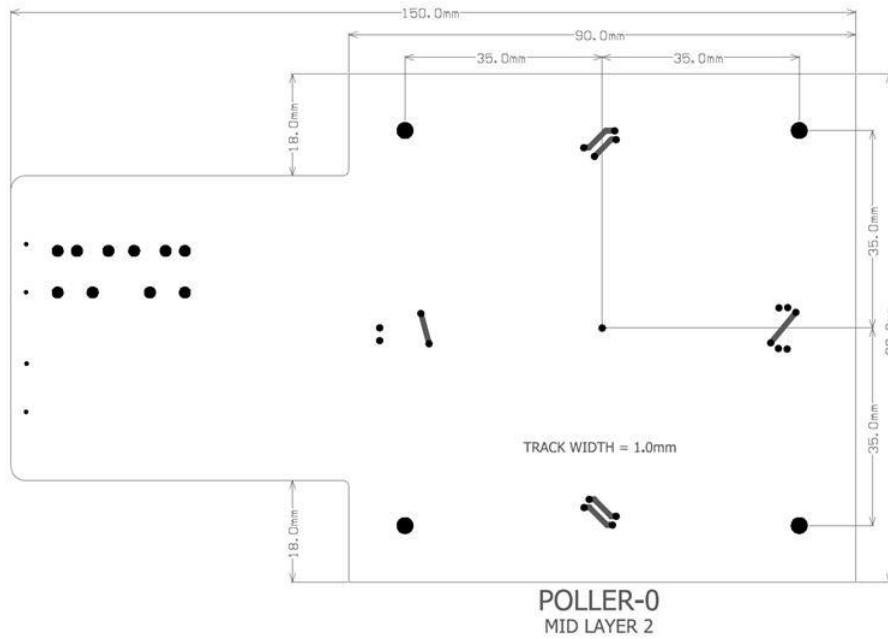

Figure 39: Reference Poller-0 Mid Layer 2

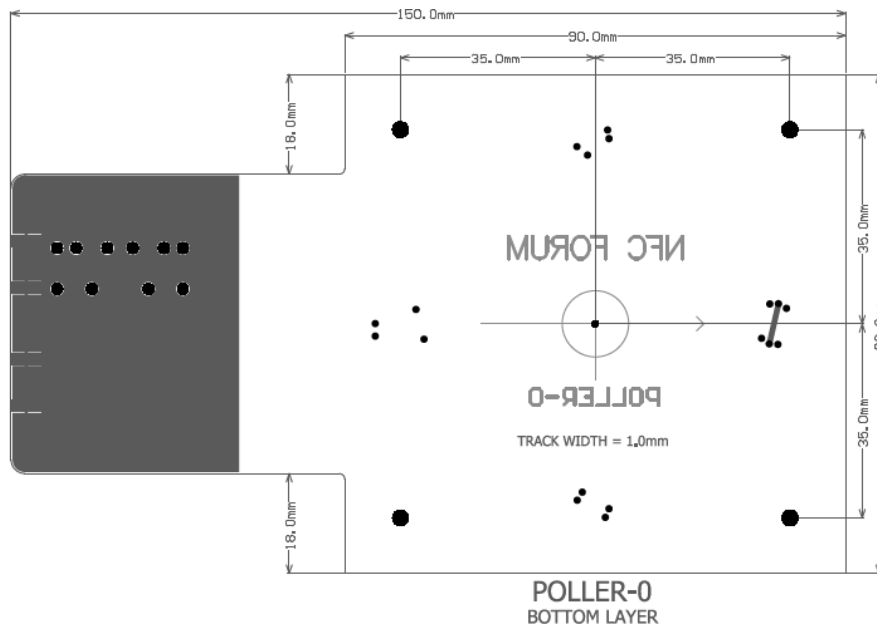

Figure 40: Reference Poller-0 Bottom Layer

and 8-Shaped Coil

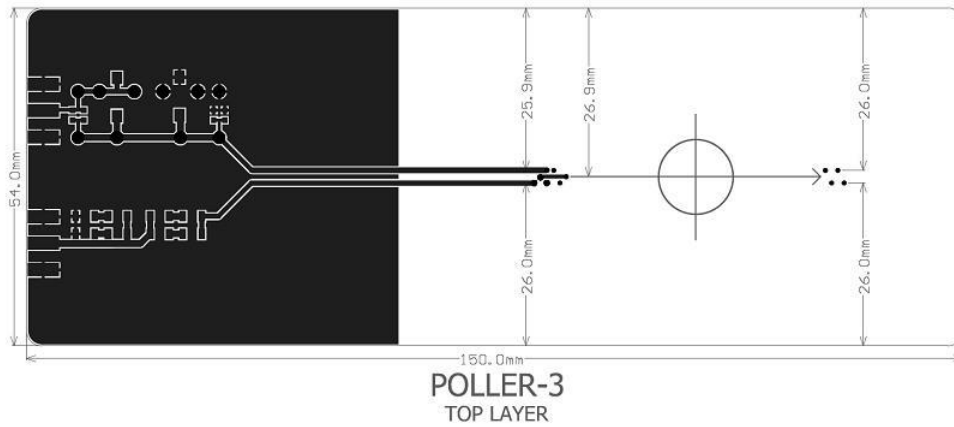

Figure 41: Reference Poller-3 Top Layer

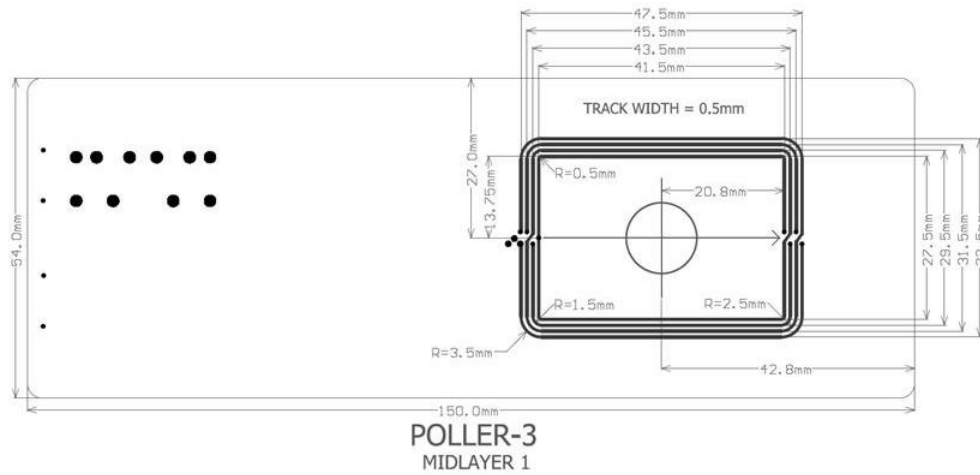

Figure 42: Reference Poller-3 Mid Layer 1

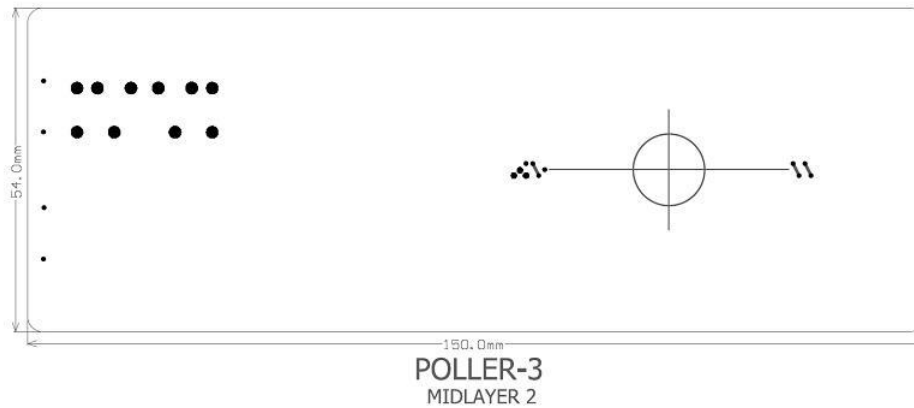

Figure 43: Reference Poller-3 Mid Layer 2

and 8-Shaped Coil

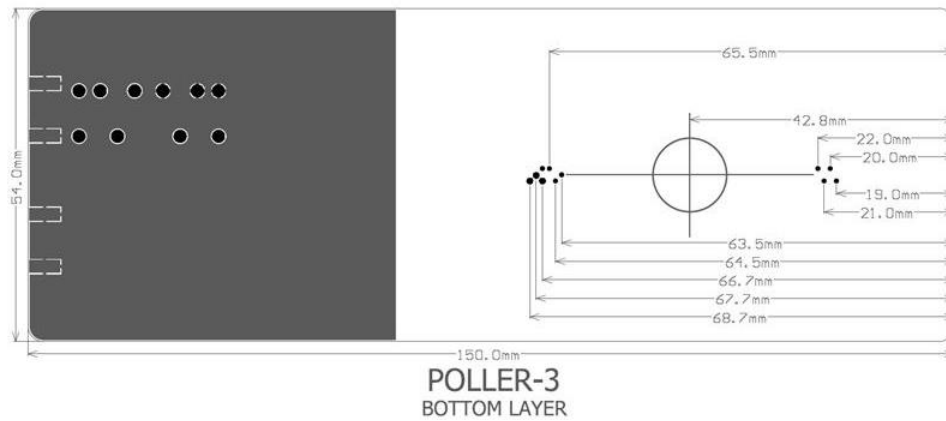

Figure 44: Reference Poller-3 Bottom Layer

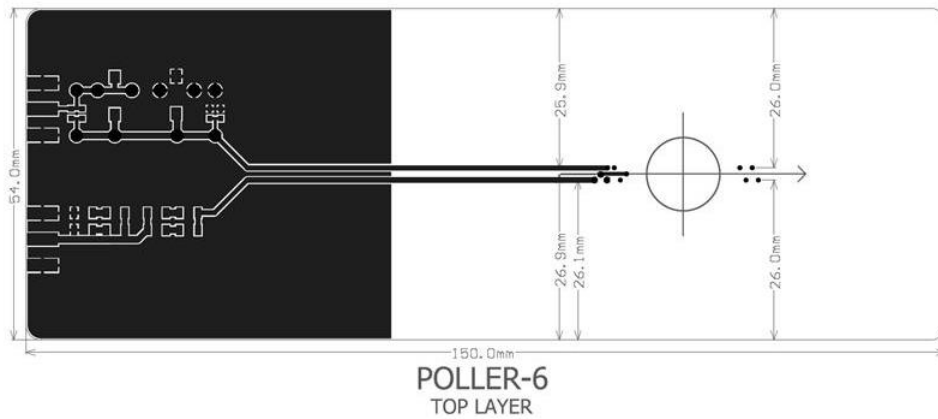

Figure 45: Reference Poller-6 Top Layer

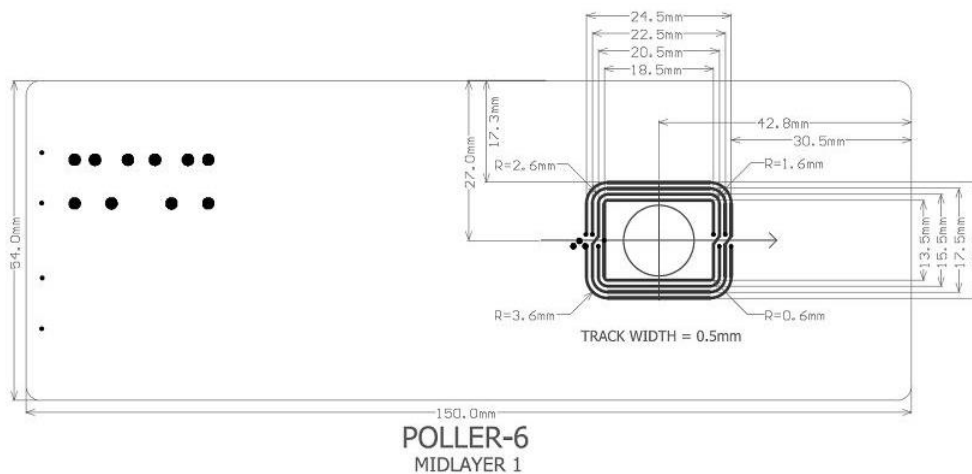

Figure 46: Reference Poller-6 Mid Layer 1

and 8-Shaped Coil

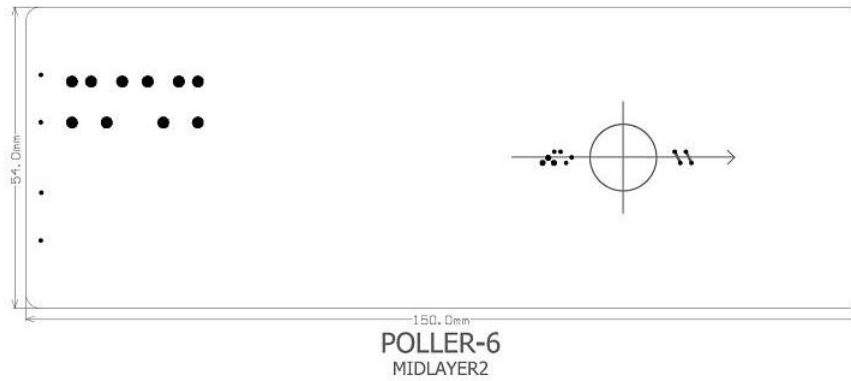

Figure 47: Reference Poller-6 Mid Layer 2

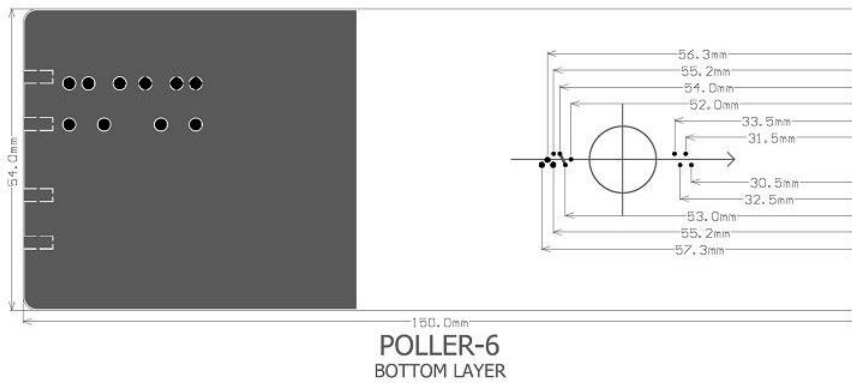

Figure 48: Reference Poller-6 Bottom Layer

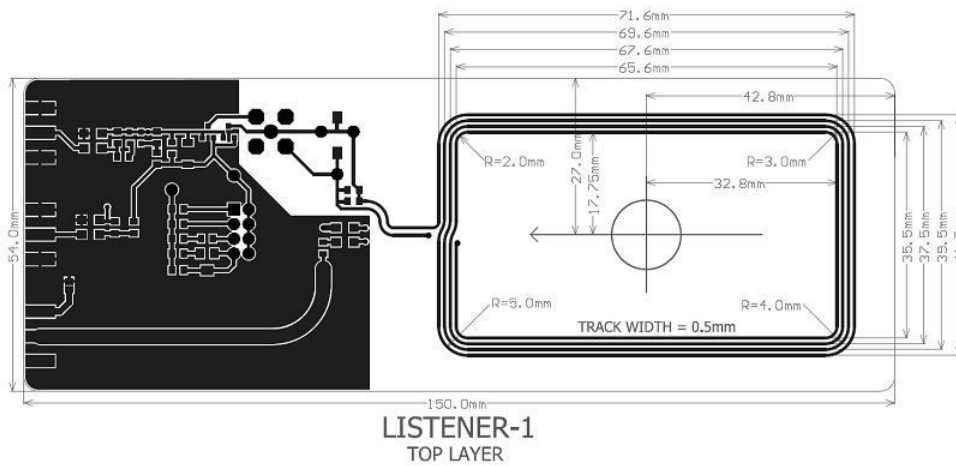

Figure 49: Reference Listener-1 Top Layer

and 8-Shaped Coil

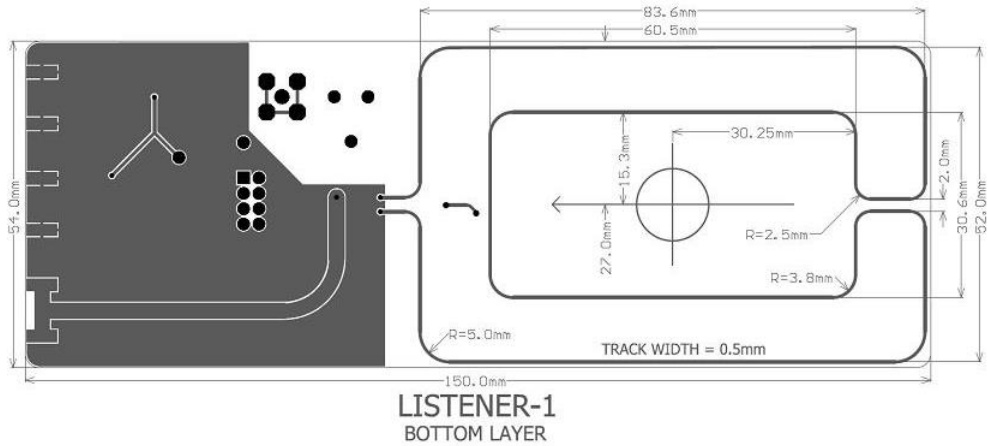

Figure 50: Reference Listener-1 Bottom Layer

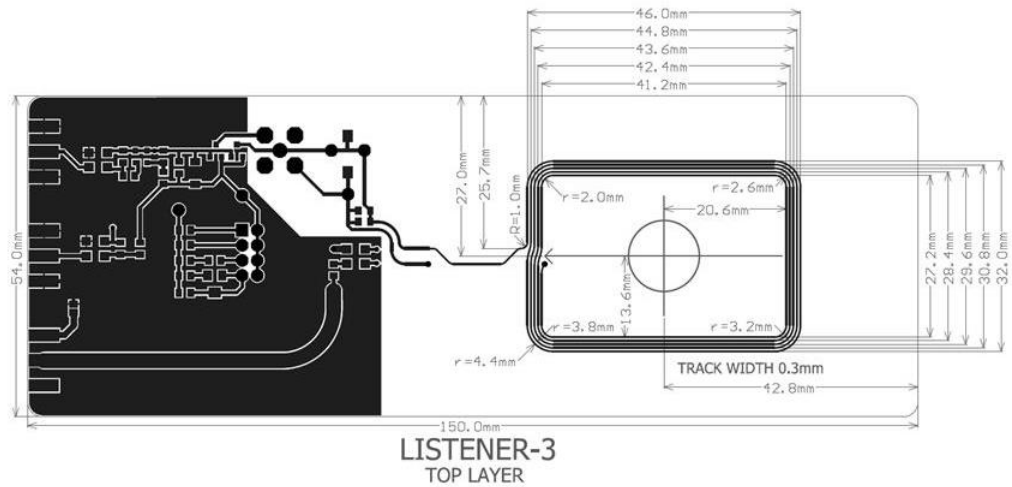

Figure 51: Reference Listener-3 Top Layer

and 8-Shaped Coil

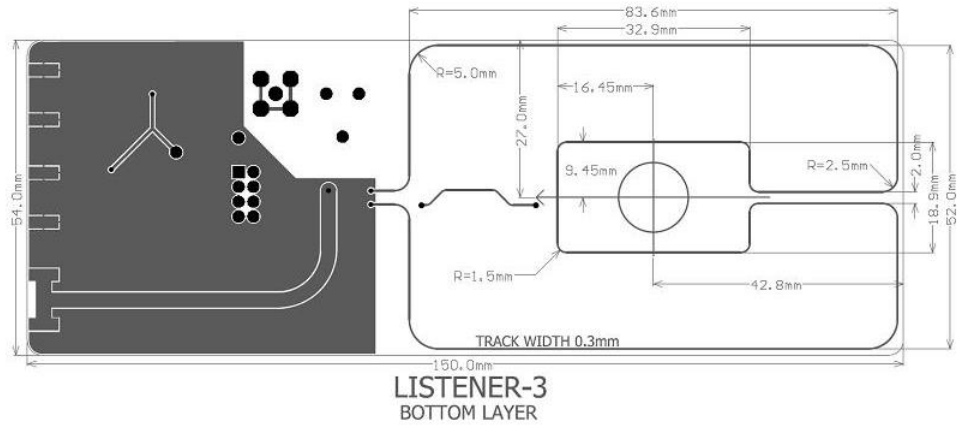

Figure 52: Reference Listener-3 Bottom Layer

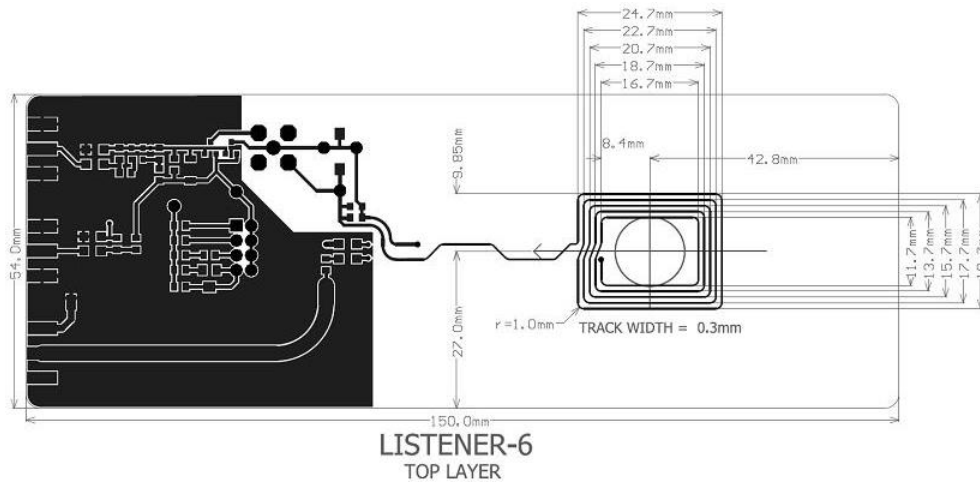

Figure 53: Reference Listener-6 Top Layer

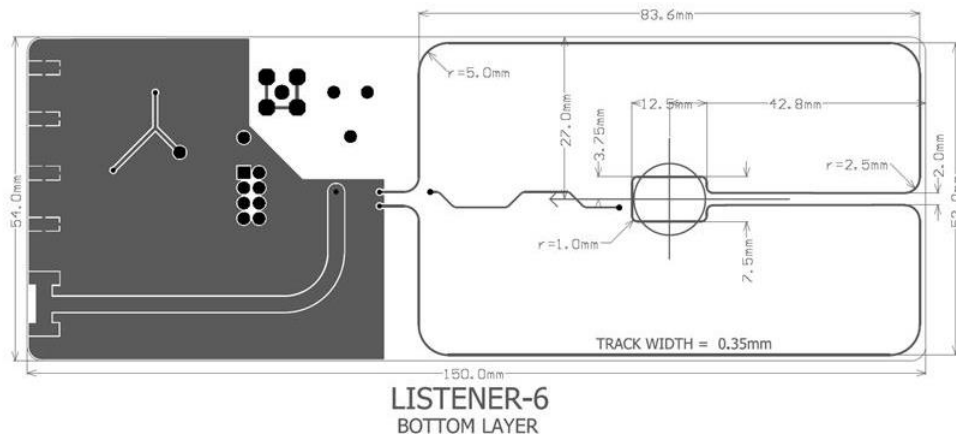

Figure 54: Reference Listener-6 Bottom Layer



and 8-Shaped Coil

Design Information for NFC Forum Reference Equipment

and 8-Shaped Coil

C.10 Printed Circuit Board (PCB) Construction of Pollers and Listeners

To maintain consistency, all Reference Pollers are constructed as nominally 1.6 mm thick, 4-layer PCBs in order to maintain the uniform characteristics specified in Appendix B.4:

- Overall thickness tolerance +/-10%.
- Dielectric constant (Dk) of FR4 cores: 4.55
- Dielectric constant (Dk) of FR4 prepregs: 4.2
- Outer Layer (1 oz Cu weight): 18 microns (before plating) and 35 microns (after plating)
- Layer 1-2 spacing of copper layer: 0.22 mm
- Inner Layer copper weight: 35 microns
- Layer 2-3 spacing of copper layer: 0.99 mm
- Inner Layer copper weight: 35 microns
- Layer 3-4 spacing of copper layer: 0.22 mm
- Outer Layer (1 oz Cu weight): 18 microns (before plating) and 35 microns (after plating)

All Reference Listeners are constructed as nominally 0.8 mm thick, 2-layer PCBs in order to maintain the uniform characteristics specified in Appendix B.6:

- Overall thickness tolerance: +/-10%.
- Dielectric constant (Dk) of FR4 cores: 4.55
- Dielectric constant (Dk) of FR4 prepregs: 4.2
- Outer Layers (1 oz Cu weight): 18 microns (before plating) and 35 microns (after plating)

Example PCB Control Drawings for the Reference Poller-0 and the Reference Listener-1 are given in Figure 55 and Figure 56.

The other Reference Pollers and Reference Listeners are consistent.

and 8-Shaped Coil

PCB CONTROL DRAWING	
BOARD SIZE :	90 x 150 mm
SUBSTRATE MATERIAL :	FR4
NUMBER OF LAYERS :	4
COMPONENTS ON TOP LAYER :	YES
SOLDER RESIST COLOUR :	GREEN
SILK SCREEN COLOUR TOP :	WHITE
COPPER THICKNESS OUTER LAYERS :	1oz/5Q
PAD FINISH :	Silver Immersion RoHS
TOTAL NUMBER OF HOLES :	38
VIA HOLE TYPES :	PTH
LEAD FREE (RoHS) :	YES
FLAMMABILITY :	UL94-V0
SUBSTRATE THICKNESS :	1.6mm
COMPONENTS ON BOTTOM LAYER :	NO
SOLDER RESIST :	BOTH SIDES
SILK SCREEN COLOUR BOTTOM :	WHITE
COPPER THICKNESS INNER LAYERS :	N/A
NUMBER OF VIAS :	22
NUMBER OF DIFFERENT DRILL SIZES :	4 (0.4mm, 0.8mm, 1mm, 3mm)
THIS PCB IS CONSTRUCTED FROM THE FOLLOWING GERBER FILES :	
PROTEL DATABASE :	Allium Structure
TOP SOLDER RESIST :	E5010-1132-01 Poller-0.GTS
TOP COPPER :	E5010-1132-01 Poller-0.GTL
MID COPPER LAYER 1 :	E5010-1132-01 Poller-0.G1
MID COPPER LAYER 3 :	NA
MID COPPER LAYER 5 :	NA
MID COPPER LAYER 7 :	NA
MID COPPER LAYER 9 :	NA
MID COPPER LAYER 11 :	NA
BOTTOM COPPER :	E5010-1132-01 Poller-0.GBL
NAME :	E5010-1132-01 Poller-0
TOP SILK SCREEN :	E5010-1132-01 Poller-0.GTO
MID COPPER LAYER 2 :	E5010-1132-01 Poller-0.G2
MID COPPER LAYER 4 :	NA
MID COPPER LAYER 6 :	NA
MID COPPER LAYER 8 :	NA
MID COPPER LAYER 10 :	NA
MID COPPER LAYER 12 :	NA

Figure 55: PCB Control Drawing for Reference Poller-0

PCB CONTROL DRAWING	
BOARD SIZE :	54 x 150 mm
SUBSTRATE MATERIAL :	FR4
NUMBER OF LAYERS :	2
COMPONENTS ON TOP LAYER :	YES
SOLDER RESIST COLOUR :	GREEN
SILK SCREEN COLOUR TOP :	WHITE
COPPER THICKNESS OUTER LAYERS :	1oz/30
PAD FINISH :	Silver Immersion RoHS
TOTAL NUMBER OF HOLES :	31
VIA HOLE TYPES :	PTH
LEAD FREE (RoHS) :	YES
FLAMMABILITY :	UL94-V0
SUBSTRATE THICKNESS :	0.8mm
COMPONENTS ON BOTTOM LAYER :	NO
SOLDER RESIST :	BOTH SIDES
SILK SCREEN COLOUR BOTTOM :	WHITE
COPPER THICKNESS INNER LAYERS :	N/A
NUMBER OF VIAS :	13
NUMBER OF DIFFERENT DRILL SIZES :	3 (0.4mm, 1mm, 1.5mm)
THIS PCB IS CONSTRUCTED FROM THE FOLLOWING GERBER FILES :	
PROTEL DATABASE :	Altium Structure
TOP SOLDER RESIST :	E5010-1152-01 Listener-1.GTS
TOP COPPER :	E5010-1152-01 Listener-1.GTL
MID COPPER LAYER 1 :	NA
MID COPPER LAYER 3 :	NA
MID COPPER LAYER 5 :	NA
MID COPPER LAYER 7 :	NA
MID COPPER LAYER 9 :	NA
MID COPPER LAYER 11 :	NA
BOTTOM COPPER :	E5010-1152-01 Listener-1.GBL
BOTTOM SOLDER RESIST :	E5010-1152-01 Listener-1.GBS
DRILL GERBERS :	E5010-1152-01 Listener-1.GG1
DRILL CNC :	E5010-1152-01 Listener-1.DRR
BOARD OUTLINE :	E5010-1152-01 Listener-1.GM1
TOP SILK SCREEN :	E5010-1152-01 Listener-1
MID COPPER LAYER 2 :	NA
MID COPPER LAYER 4 :	NA
MID COPPER LAYER 6 :	NA
MID COPPER LAYER 8 :	NA
MID COPPER LAYER 10 :	NA
MID COPPER LAYER 12 :	NA
BOTTOM SILKSCREEN :	E5010-1152-01 Listener-1.OB0
APERTURE FILE :	E5010-1152-01 Listener-1.APR
HAVE THESE FILES BEEN COMPRESSED INTO A SINGLE *ZIP* FILE : Yes	
FILENAME :	E5010-1152-01 Listener-1.ZIP

Figure 56: PCB Control Drawing for Reference Listener-1

C.11 Mechanical Dimensions and PCB Construction of 8-Shaped Coil

The 8-Shaped Coil SHALL capture the signal from the Poller. The coil is constructed of two turns: one is arranged clockwise and the other counterclockwise. When measured from the center of the tracks, the diameter of each turn SHALL be 15 mm (see Figure 57).

The 8-Shaped Coil SHALL be mounted on a FR4 epoxy substrate (prepreg) of 18 mm x 33 mm.

The 8-Shaped Coil including the FR4 prepreg SHALL be constructed as nominally 0.4 mm thick, 2-layer PCBs in order to maintain uniform characteristics.

The length of the feeding network (distance between the 8-Shaped Coil and the termination connector) SHALL be 200 mm.

The feeding network thickness SHALL be 0.25 mm and the track routing SHALL be as illustrated in Figure 57.

The termination connector SHALL be mounted on an FR4 prepreg with a thickness ≥ 0.4 mm.

Overall thickness tolerance: $\pm 10\%$.

- Track width: 0.4 mm (coil and feeding tracks)
- Dielectric constant (Dk) of FR4 cores: 4.55
- Dielectric constant (Dk) of FR4 prepregs: 4.2
- Outer Layers (1 oz Cu weight): 18 microns (before plating) and 35 microns (after plating)

The signal across the two ends (available on the termination connector) is measured by means of an oscilloscope probe that has a capacitive loading ≤ 12 pF, so as to make the self-resonant frequency ≥ 80 MHz.

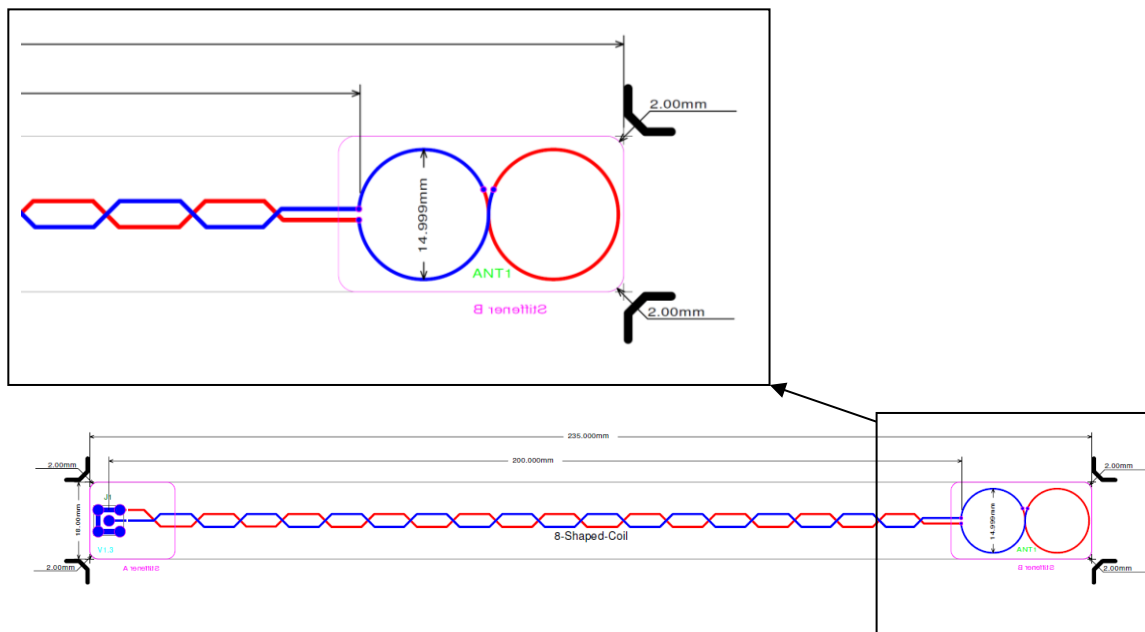

Figure 57: 8-Shaped Coil

This 8-Shaped Coil is positioned on the outside surface of the poller device, where the maximum field is induced (the most likely position will be above the actual turns of antenna or coupler coil of the poller device; see Figure 58).

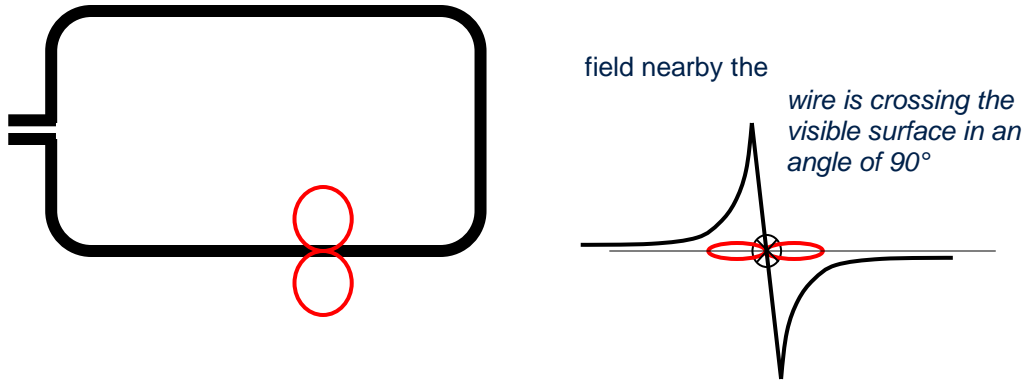

Figure 58: Principle of Operation of 8-Shaped Coil

D. Alternative Method for Measuring V_{OV} Levels

This appendix is informative and is only intended to give advice on the use of this specification during testing in ambient temperatures.

The Reference Listener specified in this document has many useful functions for NFC characterization, including V_{OV} . It has been designed to be used in a lab environment in the temperature range of 23 ± 3 °C.

Chip manufacturers will need to characterize their NFC components for adequate drive level. The best way is with a Reference Listener. However, the temperature range over which the components need to be operated is much wider than this, typically -40 to +120 °C (the usual design goal for all chips) during evaluation in an environmental chamber.

Many components in the Reference Listener board were not designed for operation over this wide temperature range. If, for example, the Reference Listener is subjected to temperature variation, then the forward voltages across the rectifying diodes will vary by about 1 mV/°C, so that the observed V_{OV} that is developed across two diodes will vary by about 2 mV/°C. Over a narrow temperature variation this change can be ignored, but over a range of 160 °C, for instance, it will produce a variation of about 320 mV, which is an unacceptably large variation.

This appendix, therefore, proposes an additional circuit block for the present Reference Listener. This circuit block will switch out all the temperature sensitive components during a V_{OV} evaluation and will switch in a less temperature sensitive potential divider that, in conjunction with an oscilloscope, will allow V_{OV} to be measured more accurately.

D.1 New V_{OV} Monitor Circuit Description

The aim of the suggested circuit is to allow, while using as few components as possible, a calibrated test instrument to measure the voltage developed across the defined load while harvesting power from a local magnetic field.

In any design the addition of a large number of components in any circuit affects the nodal voltages due to component tolerance. If the component tolerance is also temperature sensitive, then large variations in level are possible. The new monitor circuit, with the aid of links, allows the standard functionality of the Reference Listener to be temporarily disconnected and a potential divider to be inserted.

The parallel resistance of the divider is aimed to produce a load resistance of 820 Ω when a 50 Ω load is connected to the new SMA SK1 connector, as shown in Figure 59.

A 50 Ω RF cable is connected from the SK1 to the 50 Ω input of an oscilloscope that can then be used to measure the peak voltage across the 820 Ω load. The benefit of this type of connection is that the normal capacitance associated with a cable is effectively neutralized and does not affect the tuning of the resonant circuit. This enables the V_{OV} level to be measured at a remote location using a long (enough) 50 Ω cable, so that measurements within a temperature chamber can be made.

The variable capacitor used in the Reference Listener is temperature stable enough for it to have a negligible effect on accuracy. This is also true of the printed 2.4 μ H inductor that is resident on the Reference Listener-1 and the Reference Listener-3.

The Reference Listener-6 has a differently valued inductor, but the required load resistance for a V_{OV} measurement is still 820 Ω , so the new monitor circuit is still applicable.

Figure 59 also shows the waveforms that would be expected to be seen in the new circuit. Although the drawn waveforms do not appear sinusoidal, they are intended to be so. The present V_{OV} value is approximately the full wave rectified version (lower trace) of the Tag harvested voltage (upper trace). The forward diode drop of two diodes in the full-wave rectifier will be 0.6 V, so that for a specified V_{OV} level of 4.1 V the required specified peak voltage level is 4.7 V.

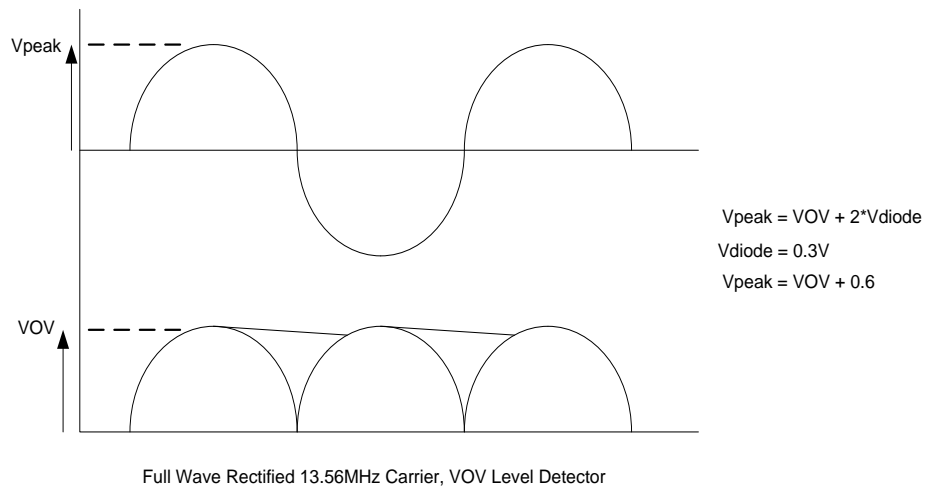
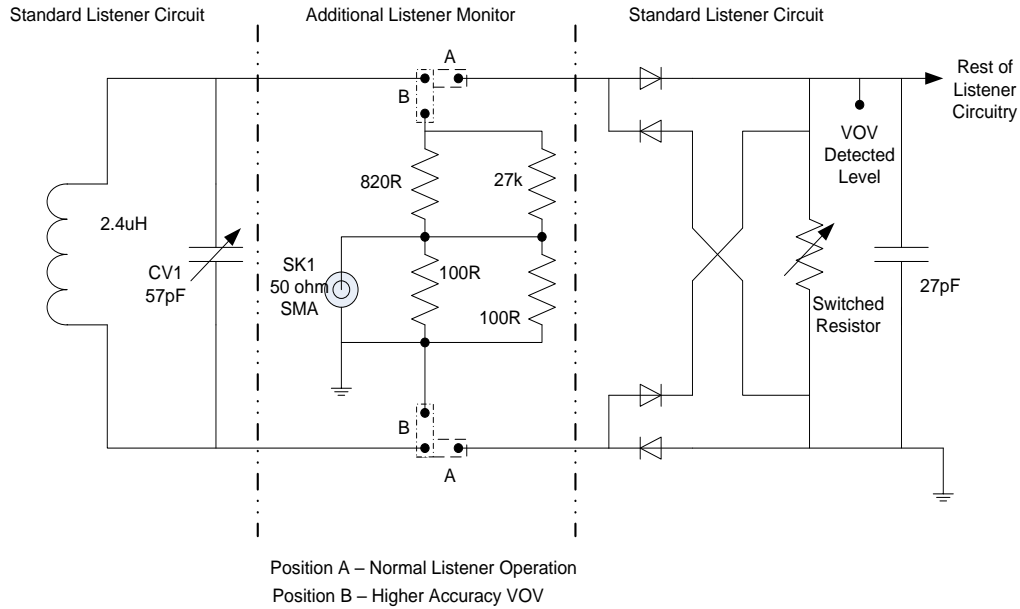

Figure 59: Suggested Additional Circuit Arrangement

The value of the voltage reduction due to the potential divider is $(25/820)$, or an attenuation of 30.3 dB. This will need to be measured for each device, due to the tolerance of the resistors used. It is recommended that a calibration sticker be attached to the PCB with the attenuation value.

For levels of voltage around 4V peak, this produces at an oscilloscope measured voltages of 122 mV peak.

The following procedure can be used to implement the alternative V_{OV} measurement procedure that will prevent temperature variations from generating excessive measurement error. Due also to the reduction in the number of components between the input antenna and the V_{OV} measurement node, the accuracy of a basic V_{OV} measurement will also be improved. The fundamental usefulness of the Reference Listener is not affected by the presence of the additional monitor, as it is switched out when it is not required.

D.2 Alternative V_{OV} Measurement Procedure

1. Reconnect the links at position A/B from position A to position B.
2. Connect a 50 Ω oscilloscope to SK1 using a 50 Ω cable.
3. Refer to the standard Listener documentation and follow the procedure to adjust the variable capacitor CV1.
4. Place the device in the magnetic field to be characterized and monitor the peak voltage detected on the oscilloscope.
5. To comply with the specifications of the NFC Forum that are detailed in the specification shown in Table 6, the measured peak voltage SHALL be $(V_{OV} + 0.6)$ V.
6. After the V_{OV} measurements have been completed, ensure that the link positions are moved back from position B to position A.
7. It might be necessary to readjust CV1 in accordance with the Reference Listener documentation.

E. Revision History

Table 15 outlines the revision history of the Analog Technical Specification.

Table 15: Revision History

Document Name	Revision and Release Date	Status	Change Notice	Supersedes
Analog	Version 1.0, July 2012	Final		
Analog	Version 1.1, February 2015	Final	ΔVOV replaced by DVR (aka ΔVOVratio) in Appendix B.2. Requirement 4.3.2.1 modified. Replace obsolete component in Figures 23, 25, and 27.	Analog V1.0 July 2012
NFC Analog Specification	Version 2.0 July 2016	Final	Inclusion of NFC-V technology Inclusion of V_{S,OV,MAX10} and V_{S,OV,MAX12} Field activation and deactivation V_{OV,RESET} Aligned V_{LMA} values for Listeners Aligned V_{OV,MIN} values for Pollers Inclusion of Antenna Categories A, B, C Changed BoM for Reference Listeners (BZV55C27 instead of BZV55C15)	Analog V1.1 February 2015
NFC Analog Specification	Version 2.1 June 2017	Final	Alignment of mod_{i,B} and mod_{i,F} Alignment of V_{OV,RESET} and V_{S,OV,RESET} Inclusion of T5T Platform Listen side requirements Inclusion of fres for Reference Listener 1,3 and 6 Inclusion of V_{S,OV,RESET,T5T} Alignment of Terms and Definition to TC Glossary Editorial update.	Analog V2.0 July 2016
NFC Analog Specification	Version 2.1 January 2018	Final	Correction of mS,i,B and mS,i,F min values	Analog V2.1 June 2017
NFC Analog Specification	Version 2.1 August 2018	Final	Correction of Modulation Poller-> Listener NFC-V Correction of 8-Shaped Coil and V _{s,ov} for Poller 6	Analog V2.1 January 2018
NFC Analog Specification	Version 2.1 August 2018	Final	V _{S,OV,RESET} for P3 and P6 TS,1,V. Editorial updates	Version 2.1 August 2018
NFC Analog Specification	Version 2.2 July 2021	Final	Inclusion of V_{S,OV,RESET,T5T} ; Inclusion of V_{S,OV,RESET} ; Note to Requirement 4.7; nominal value for ts,1,v ; Editorial Changes; T1T removal	Version 2.1 August 2018
NFC Analog Specification	Version 2.3 February 2023		Figure 1 update. Inclusion of 8-Shaped Coil in Glossary. 8-Shaped Coil as mandatory part of Reference Equipment. Editorial update.	Version 2.2 July 2021